

HOWE®

#Howelce®

Rapid Freeze® **Ice Flaker**

Installation & Service Manual

For Use with CO₂ Parallel Compressor Rack System

4000-RL-CO₂DX

6000-RL-CO₂DX

Howe Corporation

1650 North Elston Avenue
Chicago, IL 60642-1585

Phone: 1-773-235-0200

Fax: 1-773-235-0269

Website: www.howecorp.com

Email: howeinfo@howecorp.com

ENGINEERING GUIDELINES	3
Location Requirements	3
Electrical Requirements.....	3
Water Supply Requirements.....	3
Drain Water Piping Requirements	4
Refrigeration Requirements	5
Piping Table.....	7
Refrigerant Pipework	7
Refrigerant Pipework Insulation Requirements	7
FIELD INSTALLATION	8
Safety Information and Guidelines	8
Inspection	8
Piping	8
Field Wiring.....	9
Leak Testing	9
Evacuation	10
Installation Checklist	11
START UP AND OPERATION	12
Water Operation	12
Refrigeration Operation	15
Electrical Operation.....	17
Mechanical Operation	22
Start-Up Checklist.....	25
MAINTENANCE	27
Preventative Maintenance Schedule	27
Cleaning Procedure	28
Sanitizing Procedure.....	29
Lubrication	30
Water Filtration.....	31
Electronic Valve Settings	33
TROUBLESHOOTING.....	35
APPENDIX.....	38

IMPORTANT

THE INFORMATION FOUND IN THIS MANUAL IS INTENDED FOR USE BY INDIVIDUALS POSSESSING EXPERIENCED BACKGROUNDS IN ELECTRICAL, REFRIGERATION AND MECHANICAL REPAIR AND MAINTENANCE. ANY ATTEMPT TO REPAIR OR ALTER THIS EQUIPMENT MAY RESULT IN PERSONAL INJURY OR PROPERTY DAMAGE. THE MANUFACTURER IS NOT RESPONSIBLE FOR THE INTERPRETATION OF THE INFORMATION CONTAINED HEREIN, NOR HAS THE MANUFACTURER ASSUMED ANY LIABILITY IN CONNECTION WITH ITS USE.

THE MANUFACTURER IS NOT RESPONSIBLE FOR ANY LOSS, DAMAGE OR INJURY CAUSED AS A RESULT OF EITHER (I) ANY REPAIR OR REPLACEMENT TO THE MANUFACTURER'S EQUIPMENT THAT IS DONE BY A THIRD PARTY NOT PREVIOUSLY APPROVED BY THE MANUFACTURER, OR (II) ANY REPAIR OR SERVICE WORK PERFORMED ON ANY OF THE MANUFACTURER'S EQUIPMENT WHICH DOES NOT STRICTLY FOLLOW THE PROCEDURES SET FORTH HEREIN.

THE KIND OF REFRIGERANT EMPLOYED IN THE SYSTEM SHALL COMPLY WITH THE STANDARD FOR REFRIGERANTS UL 2182.

Engineering Guidelines

Location Requirements

Howe Rapid Freeze Ice Flakers are designed to operate in ambient room temperatures between 50°F (10°C) and 100°F (38°C).

Minimum Ambient Temperature	Maximum Ambient Temperature
50°F (10°C)	100°F (38°C)

The Ice Flaker warranty is void if it is installed in ambient room temperatures below 50°F (10°C).

The Ice Flaker must be located above a sanitary sewer floor drain hub or trench drain to ensure proper drainage to the floor.

Many designers slope floors to the sanitary sewer inlets to manage these wet areas.

If installing the Ice Flaker with a Howe Ice Bin, ensure that the bin is adequately secured to the floor so as to prevent the assembly from tipping when empty.

Electrical Requirements

A dedicated 15 amp power supply from a field furnished and installed disconnect switch is required for each Ice Flaker.

Water Supply Requirements

Cold water supply to the Ice Flaker must be totally separate and unaffected by any local hot water supply.

This cold water supply must be within the range of 45°F (7°C) to 90°F (32°C).

Minimum Water Supply Temp.	Maximum Water Supply Temp.
45°F (7°C)	90°F (32°C)

The cold water supply pressure must be within a 20 PSIG (140 kPa) to 60 PSIG (410 kPa) range.

Minimum Water Pressure	Maximum Water Pressure
20 PSIG (140 kPa)	60 PSIG (410 kPa)

Straight Reverse Osmosis (RO) treated water should never be supplied to the Ice Flaker.

RO system treated water is aggressive toward metals and plated surfaces. In addition RO water will affect the life and integrity of rubber and plastic material Ice Flaker components. If only RO water is available, Post-RO treatment must be provided to raise pH and mineral content.

Generally, filtration of cold supply water is recommended. Howe offers a complete line of replaceable core cartridge filter treatment systems designed to improve ice quality and extend the life of the Ice Flaker.

This filtration will also reduce supply water related service problems if changed at least every six months or depending upon local water conditions.

A dedicated 1/2" ODS copper cold water supply should be located within 4 feet of the Ice Flaker complete with hand shut off valve.

A 3/8" OD copper tube should connect the field installed shut off valve with the Ice Flaker water inlet connection located at the rear of the machine.

Drain Water Piping Requirements

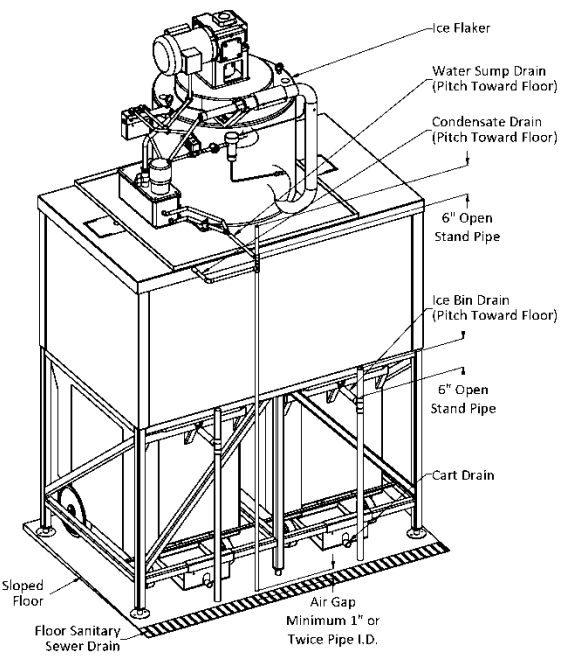

The Drain Water Piping figure above illustrates the recommended piping to a floor sanitary sewer hub or trench drain. The two vertical pipe drops should drain water through an indirect water connection with an "Air Gap". Code authorities having jurisdiction may dictate other indirect water connection requirements.

The figure depicts two separate drain lines which are required to ensure the Ice Flaker does not inadvertently flow Water Sump Drain water into the Ice Bin or Carts in the event of a backup or any other malfunction.

Refrigeration Requirements

Model	Refrigeration Requirements*	Optimum Evaporator Temperature
4000-RL-CO ₂ DX	36,000 BTU/hr (10.6 kW)	-5°F (-20.6°C)
6000-RL-CO ₂ DX	54,000 BTU/hr (15.8 kW)	-5°F (-20.6°C)

*Refrigeration requirements are based on operating the Ice Flaker with 70°F (21°C) supply water and 90°F (32°C) ambient air conditions. Refrigeration requirements and/or capacity will vary with temperatures outside these conditions.

Parallel Compressor Rack Systems

The design saturated evaporator temperature of the Ice Flaker requires connection to a low temperature remote parallel compressor rack system, or Rack.

The liquid and suction header refrigeration load station stubs serving the Ice Flaker should be equipped with ball shut-off valves only.

No suction pressure regulating valve of any type should be assigned to the Ice Flaker at the Rack or suction line branch. If a liquid line solenoid is installed at the rack or on a liquid line branch feeding the Ice Flaker, it must be a type which allows backwards flow to prevent liquid trapping between the valve and the Ice Flaker.

The Ice Flaker has its own liquid line solenoid to prevent flooding of the evaporator when the ice flaker is off.

The Ice Flaker liquid line solenoid valve as well as an Electronic Expansion Valve (EEV) and the appropriate Electric Evaporator Pressure Regulator (EEPR) valve come installed at the flaker with their own pre-programmed controls.

The Ice Flaker should always be assigned to the liquid header station closest to the main liquid feed from the refrigerant receiver. An alternate solution is to install a 1/2" liquid stub directly teed from the main liquid feed.

Racks equipped with gas defrost are not recommended for use with Howe Ice Flakers.

Both hot gas and saturated vapor defrost produce poor quality refrigerant returning to the liquid header which can result in saturated flash-gas being supplied to the Ice Flaker. If the Ice Flaker is intended to be connected to a gas defrost Rack, please take all necessary measures to prevent flash-gas from reaching the Ice Flaker.

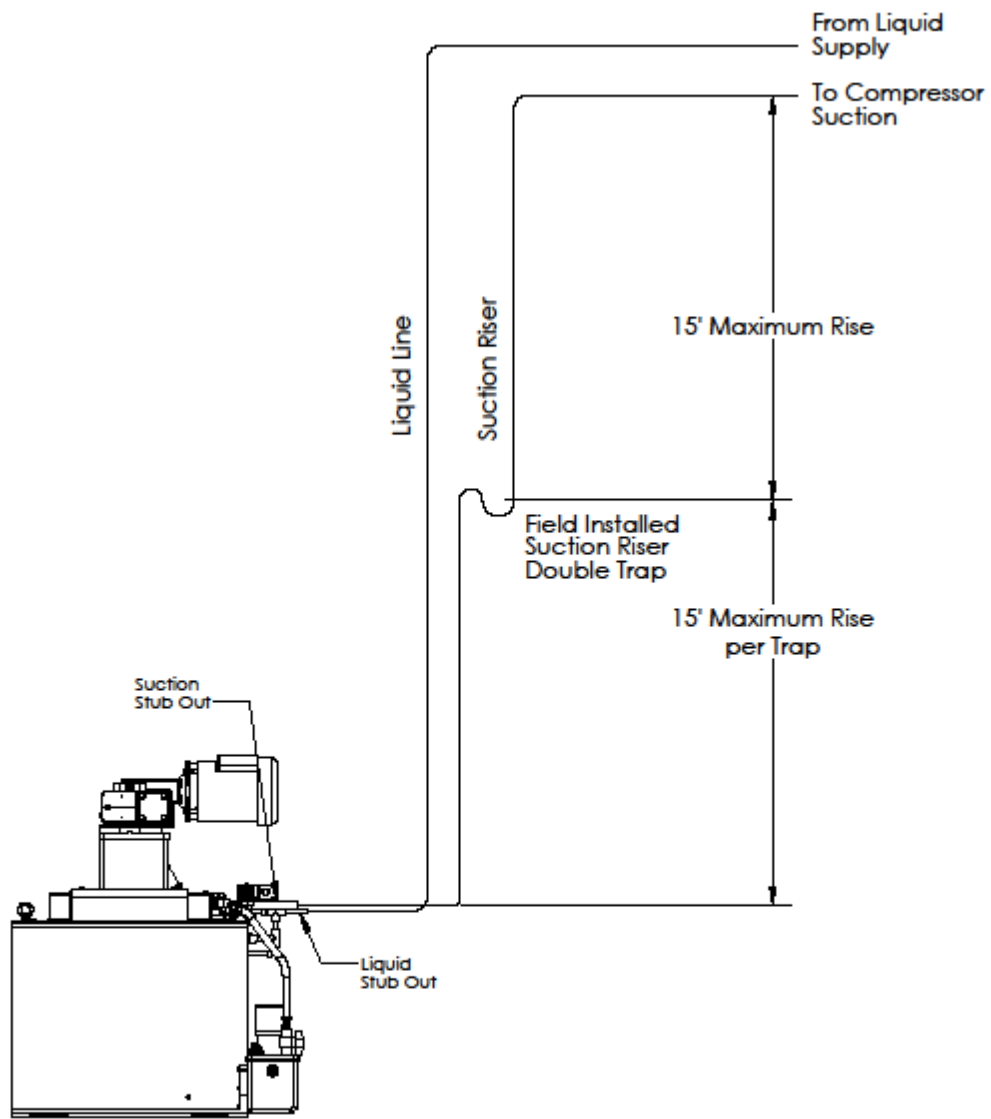

SUGGESTED REFRIGERANT PIPING DIAGRAM

Figure 1

Piping Table

Model	Liquid Line*	Suction Line*
4000-RL-CO ₂ DX	1/2" ODS	7/8" ODS
6000-RL-CO ₂ DX	1/2" ODS	1-1/8" ODS

*For runs up to 150 feet. If longer, use next larger line size.

Refrigerant Pipework

Howe recommends the field refrigerant piping be installed according to the Suggested Refrigerant Piping Diagram shown on previous page.

Howe recommends the use of hard drawn ACR type L tubing with refrigeration grade wrought copper long radius elbows and fittings only. No soft drawn tubing should be used in the refrigerant pipe installation.

No field installed P-type oil trap is required at the base of the suction riser since all Ice Flakers are internally piped with a suction trap at the outlet of the evaporator.

Installation specifications should require all refrigerant piping should be joined with a suitable silver brazing alloy while purging nitrogen through the piping to prevent copper oxidation scale from forming inside the tubing.

Refrigerant Pipework Insulation Requirements

Field refrigerant pipework should be insulated with closed cell flexible elastomeric foam thermal insulation intended for cold applications.

Liquid lines should be covered with 1/2" thick and suction lines with 3/4" thick material.

The insulation material should be moisture vapor resistant when correctly installed according to the manufacturer's instructions.

All butt joints and seams must be properly field fabricated according to the insulation manufacturer's fusing adhesive instructions.

Self-adhering closed cell foam insulation is also available in rolls and can be used to supplement the conventional tubular materials on irregular shapes.

Field Installation

Safety Information and Guidelines

Only qualified service technicians should attempt to install, service, or maintain the Ice Flaker.

Make sure all power sources are disconnected before any service work is done to the Ice Flaker.

All field wiring must conform to the requirements of the equipment and all applicable local codes and national codes.

Any liquid line solenoid valve installed at the rack should allow backwards flow in the event of liquid trapping between the valve and the ice flaker.

Inspection

Upon receipt, check all items against the bill of lading to make sure all crates and cartons are accounted for.

Any shortage or damages should be reported to the delivering carrier. Damaged material becomes the delivering carrier's responsibility and should not be returned to the manufacturer unless prior approval is given.

Take care not to damage equipment when uncrating.

Piping

The Ice Flaker has been thoroughly cleaned and dehydrated at the factory. However, foreign matter may enter the system by way of the piping to the Rack. Therefore, care must be used during installation of the piping to prevent entrance of foreign matter.

Install all refrigeration system components in accordance with applicable local and national codes and in conformance with good practice required for the proper operation of the Ice Flaker.

The refrigerant pipe size should be selected from the Piping Table. The interconnecting pipe size is not necessarily the same as the stub-out on the Rack or the Ice Flaker.

The following procedures should be followed:

1. Do not leave units or piping open to the atmosphere any longer than is absolutely necessary.
2. Use only refrigeration grade copper tubing, properly sealed against contamination.
3. Suction lines should slope 1/4" per 10 feet towards the compressor.
4. Refer to the Suggested Refrigerant Piping Diagram (p.6) for suitable P-type oil trap locations to enhance oil return to the compressor.
5. When brazing refrigerant lines, Dry Nitrogen should be passed through the line at low pressure to prevent scaling and oxidation inside the tubing.
6. Use only a suitable silver solder alloy on suction and liquid lines.

Field Wiring

All field wiring must be in compliance with local and national codes. Use only copper conductors of the appropriate size.

Two electrical Control Panels (main control panel and CO₂ EEV/EEPR control panel) are shipped loose with CO₂DX Ice Flakers. Both should be wall-mounted near the Ice Flaker for easy access.

Main Control Panel Wiring

1. Install disconnect (not supplied by factory).
2. Connect power to the terminals marked “L1” and “L2” in the main Control Panel.
3. Connect the following between the main Control Panel and the Junction Box at the Ice Flaker.

Component	Control Panel	Junction Box
Drive Motor	T1 Driv	1
	T2 Driv	2
Water Pump	T1 Pump	3
	T2 Pump	4
Solenoid Valve	Sol A1	5
	Sol A2	6
Rib Heaters*	HTR A1	7
	HTR A2	8

*Rib Heaters are an optional feature and may not be present

4. Make sure the wire jumper between the terminals marked “A” and “B” in the Control Panel is secure.
5. Connect the leads from the Photo Eye sensors to the terminals mark “Blue”, “Black”, and “Brown” in the Control Panel (see p.20).

CO₂ EEV/EEPR Control Panel Wiring

(see Wiring Diagram- CO₂ EEV/EEPR Control Panel p. 40 for wiring schematic)

1. Connect 230 V power to the wire leads labeled “L1” and “L2” in the control panel.
2. Connect the wires from the grey cable marked EEV to the following terminals on the Kelvin II controller:

Kelvin II Terminal	Wire Color
5	Black
6	White
7	Green
8	Red

3. Connect the wires from the black cable marked EEPR to the following terminals on the Pressure Control:

P. C. Terminal	Wire Color
5	Black
6	White
7	Green
8	Red

4. Connect the wires labeled T1 to terminals 31 and 32 on the Kelvin II controller.
5. Connect the wires from the cables labeled P1 and P2 to the following terminals on both controllers:

Terminal	Wire Color
33	White
34	Green
35	Black

Leak Testing

After all refrigerant connections are made, the entire system must be leak tested. Use accepted industry leak test methods.

The system should be pressurized to no more than 45 bar (653 psig).

It is recommended that this pressure be held for a minimum of 12 hours and then rechecked. For a satisfactory installation, the system must be leak tight.

Evacuation

Do not use the refrigeration compressor to evacuate the system. Do not start the compressor while it is in a vacuum.

A good, deep vacuum pump should be connected to both the low and high side evacuation valves with copper tube or high vacuum hoses (1/4" ID minimum).

If the compressor has service valves, they should remain closed.

A deep vacuum gauge capable of registering pressure in microns should be attached to the system for pressure readings.

A shut off valve between the gauge connection and vacuum pump should be provided to allow the system pressure to be checked after evacuation.

Do not turn off vacuum pump when connected to an evacuated system before closing shut off valve.

The vacuum pump should be operated until a pressure of 1,500 microns absolute pressure is reached – at which time the vacuum should be broken with the refrigerant to be used in the system through a drier until the system pressure rises above "0" psig.

Refrigerant used during evacuation cannot be vented. Reclaim all used refrigerant.

Repeat this operation a second time.

Open the compressor service valves and evacuate the entire system to 500 microns absolute pressure. Raise the pressure to 2 psig with the refrigerant and remove the vacuum pump.

Installation Checklist

1. **Has the ambient temperature been verified between 50°F – 100°F (10°C – 38°C)?**
(see Location Requirements p.3)
2. **Has the incoming water temperature been verified between 45°F – 90°F (7°C – 32°C)?**
(see Water Supply Requirements p.3)
3. **Has the water supply pressure been verified between 20 PSIG (140kPa) and 60 PSIG (410kPa)?**
(see Water Supply Requirements p.3)
4. **Has the filtered water supply been verified as not RO water?**
(see Water Supply Requirements p.3)
5. **Has the Ice Flaker been located near a floor sanitary sewer drain?**
(see Drain Water Piping Requirements p.4)
6. **Have all the refrigeration lines been sufficiently insulated?**
(see Refrigerant Pipework Insulation Requirements p.7)
7. **Have the Photo Eye sensors been connected?**
(see Field Wiring p.9)
8. **Has the CO₂ Control Panel been mounted and connected?**
(see CO₂ EEV/EEPR Control Panel Wiring p. 9)
9. **Has the system been leak tested properly?**
(see Leak Testing p.10)
10. **Has the system been evacuated properly?**
(see Evacuation p.10)
11. **Has the system been charged properly?**

Start Up and Operation

Water Operation

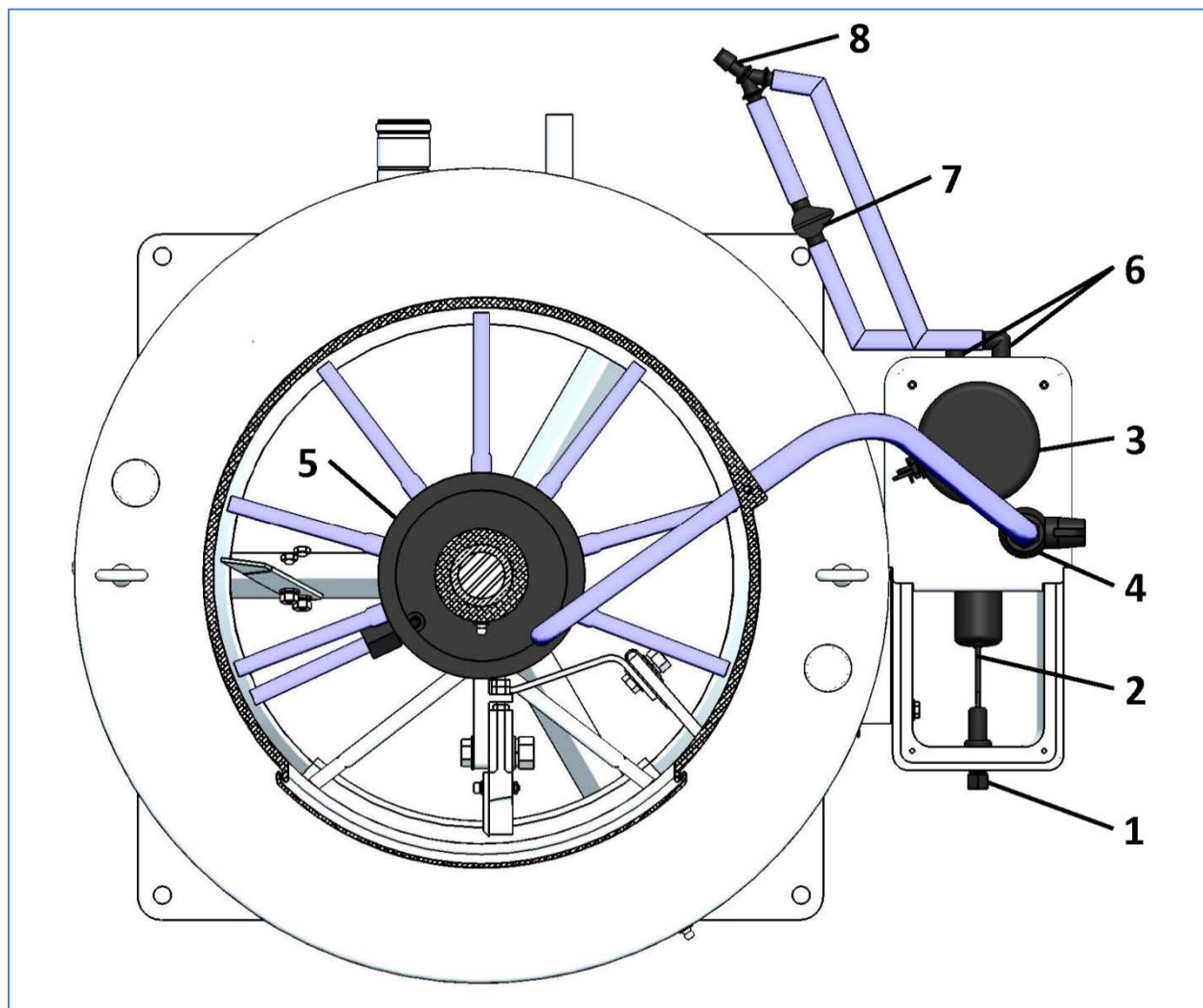

1. Water Inlet Connection
2. Float Valve
3. Water Pump
4. Water Regulating Valve
5. Water Distribution Pan & Side Spouts
6. Sump Connections
7. Stop Valve
8. Drain Outlet

Water Inlet

The supply water feed for the Ice Flaker must be connected here. A shut-off valve should be field installed before this connection.

The Ice Flaker requires a minimum water pressure of 20 PSIG (140 kPa) and a maximum of 60 PSIG (410 kPa).

Float Valve

The water level in the Water Sump is regulated by the Float Valve.

The water level should always be below the opening on the side of the Water Sump.

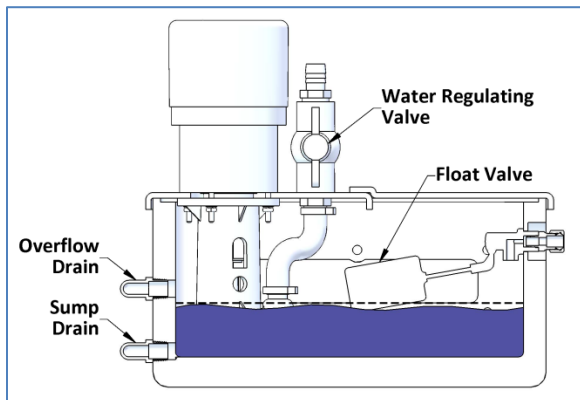

Section View of Water Sump

Water should never be allowed to flow from the Water Sump back through the opening and into the Bottom Casting.

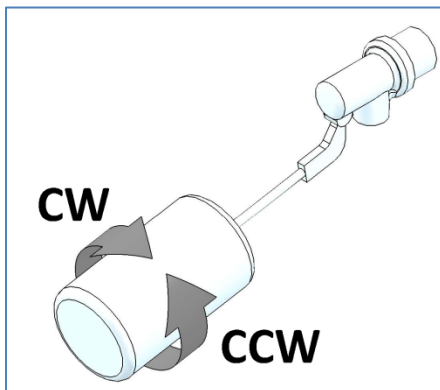

Adjust the water level by rotating the float end of the Float Valve. Rotate clockwise to raise the water level and counterclockwise to lower the water level.

Water Pump

The Water Pump drives the water in a continuous flow through the system.

The Water Pump inlet should be submerged at all times. Air should never be pulled into the intake.

Overflow Drain

The higher of the two drain connections on the Water Sump is the Overflow Drain.

If water is exiting the Water Sump through the Overflow Drain, the water level is too high and the Float Valve needs to be adjusted.

Sump Drain

The lower of the two is the Sump Drain. It is used to flush the Water Sump of all liquid.

Stop Valve

The stop valve attached to the Sump Drain fitting should always be closed during normal operation.

The stop valve should only be opened during cleaning or emptying of the Water Sump.

Water Distribution Pan

The Water Distribution Pan circulates the water fed from the Water Pump down the walls of the Evaporator.

There are two small plastic tabs on the bottom of the Water Distribution Pan. These tabs should straddle the wing of the Ice Blade to prevent it from rotating.

The tube exiting the Water Distribution Pan from the bottom is the Lead Spout. It must always be flowing with water during normal operation and pointing perpendicular to the evaporator surface.

Do not plug or cap the bottom Lead Spout.

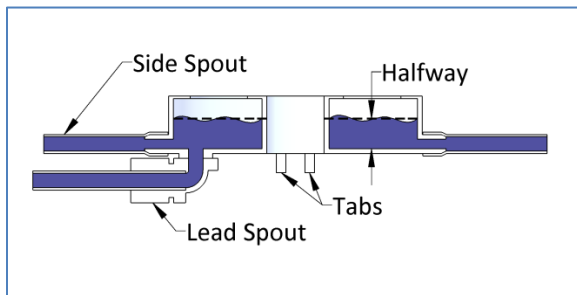

Section View of Water Distribution Pan

Water level in the Water Distribution Pan should be about halfway full. The Side Spouts should never be starved of water.

Water Regulating Valve

Adjust the water level in the Water Distribution Pan by opening or closing the Water Regulating Valve located directly above the Water Sump.

Only adjust the Water Regulating Valve after the Ice Flaker has been producing ice for at least 10 minutes.

Drain Outlet

Water exiting the Water Sump during cleaning or emptying will do so through the Drain Outlet.

The Drain Outlet must connect to a floor drain. Make sure it is clear from restrictions and flows freely.

Refrigeration Operation

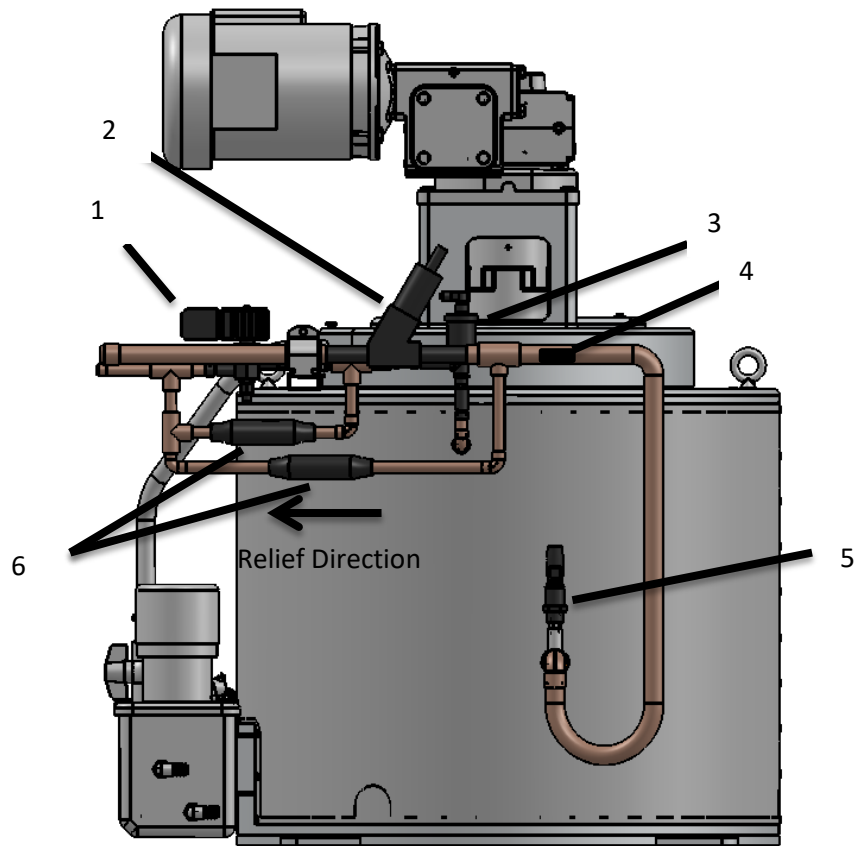

*Piping insulation not shown

1. Solenoid Valve
2. Electric Evaporator Pressure Regulator (EEPR)
3. Electric Expansion Valve (EEV)
4. Temperature Sensor
5. Pressure Transducers (2)
6. Internal Pressure Relief Valves (2)

Solenoid Valve

The Solenoid Valve controls the flow of liquid refrigerant to the Evaporator.

The Solenoid Valve should energize immediately upon starting the Ice Flaker.

The solenoid should only de-energize when the Ice Flaker is in Off-Delay Setting (p. 19) or Overload Condition (p. 19).

Electronic Valves

CO₂ flakers feature two electronic valves each controlled by a standalone controller.

The Electronic Expansion Valve (EEV) controls the flow of liquid refrigerant into the evaporator.

The Electronic Evaporator Pressure Regulator (EEPR) valve will hold the suction temperature at the proper level.

Internal Pressure Relief Valves

The Internal Pressure Relief Valves will relieve excess pressure from the evaporator to the rack.

Field Capacity Check

The Ice Flaker is a continuous production machine and makes ice at a steady rate once stabilized.

A Capacity Check confirms the Ice Flaker and refrigeration settings are correct.

1. Choose an appropriately sized container and weigh it while empty.

Container Weight _____ Lbs.

2. Run the Ice Flaker for 10 minutes.
3. Position the container below the opening of the Ice Flaker.
4. Catch the falling ice in the container for exactly 15 minutes. Be sure that the container catches all of the ice.
5. Weigh the ice and the container together in pounds using an accurate scale. Do not drain before weighing.

Measured Weight _____ Lbs.

6. Subtract the weight of the container.

Measured Weight			(from #5)
- Container Weight	-		(from #1)
= Calculated Weight	=		Lbs.

7. Calculate the capacity by multiplying the calculated weight by 96.

Calculated Weight			(from #6)
x 96	x 96		
= Capacity	=		Lbs. per 24 hrs.

8. Compare the number with the rated capacity of the Ice Flaker. Keep in mind temperatures outside the rated conditions will have an effect on the capacity.

Electrical Operation

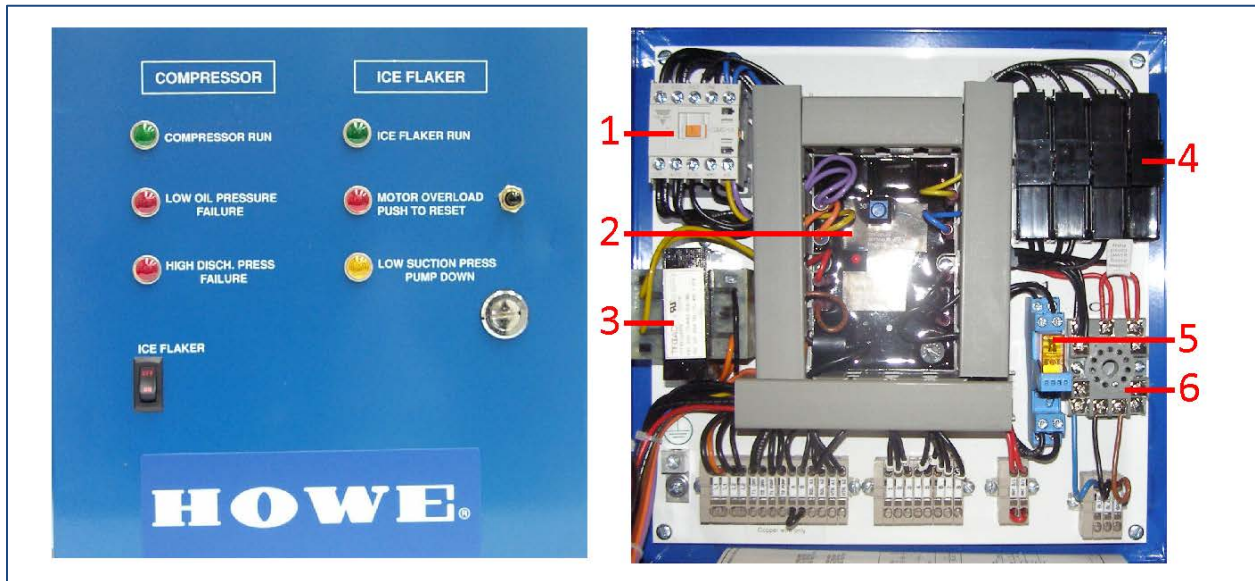

- | | |
|-------------------------|------------------------------|
| 1. Motor Contactor (M1) | 4. Fuses (FU1 & FU2) |
| 2. Control Module (CM) | 5. Water Pump Relay (R1) |
| 3. Transformer (T1) | 6. Level Control Relay (LC1) |



- | | |
|--------------------------------------|---|
| 1. Term 1: 24V Input Power | 7. Term 7: Solenoid Valve Contact |
| 2. Term 2: 24V Input Power | 8. Term 8: Solenoid Valve Contact |
| 3. Term 3: Control Signal | 9. Off-Delay Setting |
| 4. Term 4: Motor Overload Reset | 10. Motor Overload Setting |
| 5. Term 5: Motor Overload Switch Leg | 11. Overcurrent Condition Indicator Light |
| 6. Term 6: Ice Flaker Run Switch Leg | 12. Overload Sensing Coil |

Level Control Relay (LC1)

This relay processes the signal from the Photo Eyes. It shuts the Ice Flaker off when the Ice Bin is full to prevent damage caused by ice backing up into the evaporator section.

Motor Contactor (M1)

This relay provides power to the Drive Motor, the Water Pump, and the Solenoid Valve. It features a manual override button, which when depressed will engage the relay contacts, even when the relay coil is not energized.

Transformer (T1)

This provides 24 volt control power to the Control Module, Motor Relay, and indicating lights.

Water Pump Relay (R1)

This relay closes the Solenoid Valve in the event that power is unexpectedly lost to the Water Pump.

Fuses (FU1 & FU2)

The (FU1) fuses control the Water Pump and (FU2) fuses control the Rib Heaters. (FU2) fuses may not be present if the Ice Flaker is not equipped with the Low Ambient Kit option.

Ice Flaker Run Indicator Light

This is lit green during Normal Operation.

Motor Overload Indicator Light

This is lit amber when Ice Flaker is in Overload Condition. The Reset Button is a normally open switch, which resets the circuit after an Overload Condition.

Control Module (CM)

The control Module features eight wire terminals, two adjustable dials, and one indicating light.

It operates in one of three main modes:

- Normal Operation
- Off-Delay Cycle
- Overload Condition

Normal Operation

Normal Operation begins when the Control Module senses voltage at the Control Signal (Term 3).

During Normal Operation voltage is present at Ice Flaker Run Switch Leg (Term 6) and the Solenoid Valve Contacts (Term 7 & 8) are closed.

Off-Delay Cycle

The Off-Delay Cycle begins when voltage is removed from the Control Signal (Term 3).

The length of the Off-Delay Cycle is determined by the blue Off-Delay Setting dial. The increments are in minutes with 1 being the lowest possible setting and 30 being the highest.

During the Off-Delay Cycle voltage is present at Ice Flaker Run Switch Leg (Term 6) until the time setting has been met. The Solenoid Valve Contacts (Term 7 & 8) are opened when the Off-Delay Cycle is initiated.

Off-Delay Setting

Under Normal Operation the Off-Delay Setting should be adjusted to run approximately 2 minutes after the Solenoid Valve shuts off the refrigeration to the Ice Flaker.

For proper adjustment, turn knob counterclockwise until it stops. Then turn clockwise 1/8 turn and stop.

The 30 minute setting is used for Cleaning Procedure only.

Overload Condition

An Overload Condition begins when the Overload Sensing Coil reads amperage from the motor lead passing through it that is higher than the Motor Overload Setting.

During an Overload Condition no voltage is present at Ice Flaker Run Switch Leg (Term 6), the Solenoid Valve Contacts (Term 7 & 8) are open, and the Overcurrent Condition Indicator Light is lit red.

The Motor Overload setting should be adjusted on start-up and anytime changes are made to the Drive Motor or Main Shaft.

Motor Overload Setting

The proper adjustment of Motor Overload Setting will protect the Ice Flaker and help avoid nuisance service calls.

To set the Motor Overload correctly,

1. Mark the location of the setscrew before an adjustment is made, as a point of reference.
2. Place a small flat blade screwdriver in the adjustment screw while the Ice Flaker is operating.
3. Then gently and slowly turn counterclockwise until Overload Condition Indication Light illuminates. Do not force adjustment screw past bottom stop.
4. Then turn adjustment screw clockwise 1 hash mark and stop.
5. Press the reset button to start the Ice Flaker again.

Photo Eyes (Level Control)

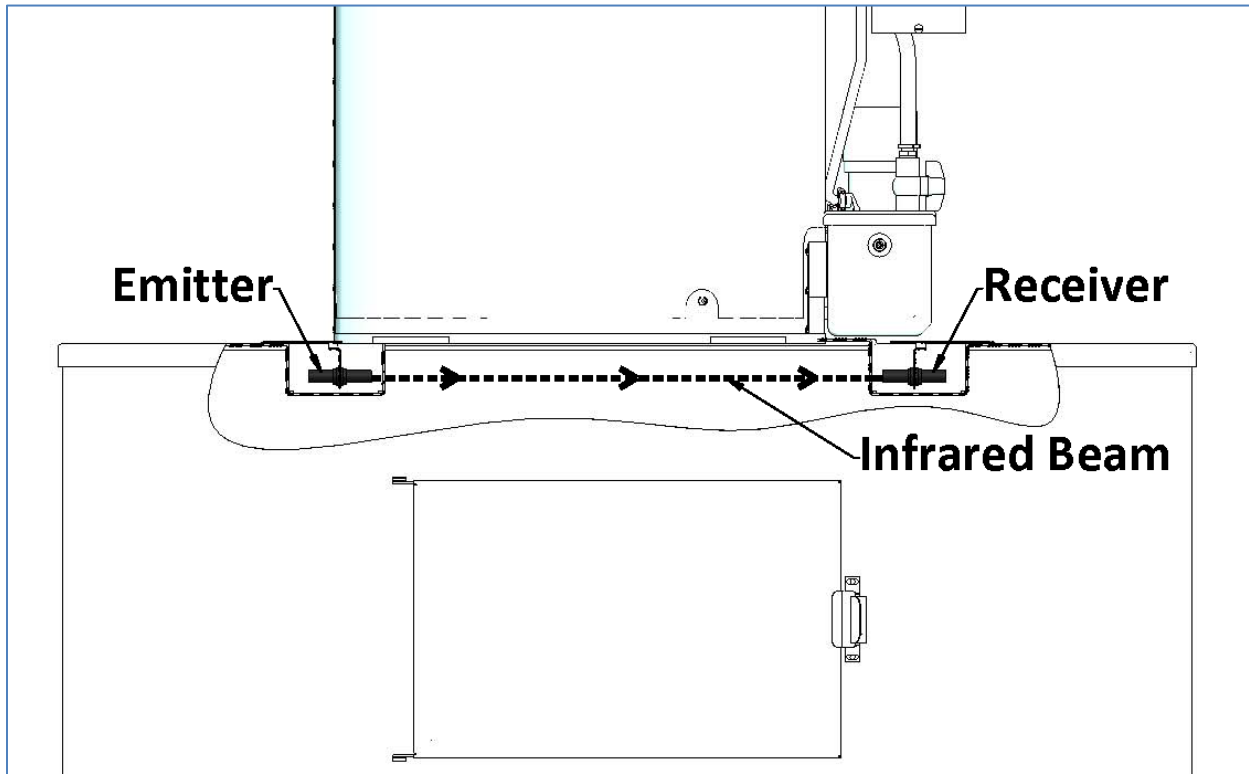
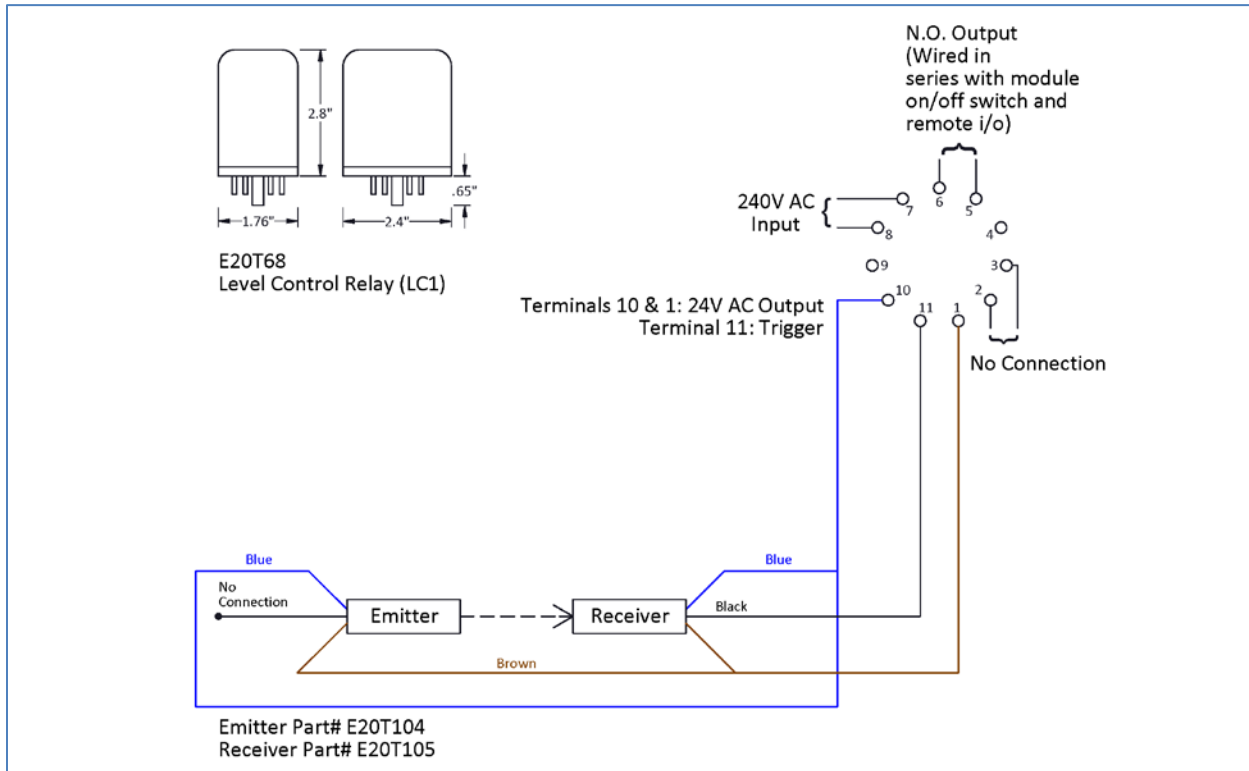

Photo Eye Wiring



The Photoelectric sensors, or Photo Eyes, shoot an infrared beam across the opening of the Ice Flaker.

If this beam is interrupted for more than 15 seconds, the Ice Flaker will begin the Off-Delay Cycle. This prevents ice from filling into the ice making area and damaging internal parts.

The Ice Flaker will return to Normal Operation when the infrared beam is re-established, provided the Off-Delay Cycle has completed.

If the Ice Flaker was purchased without an Ice Bin the Photo Eyes will be shipped loose and need to be properly mounted by the installing contractor. Please contact Howe for further information.

Water or Moisture in Molex Plug

If the Molex plug for either the Emitter or Receiver is wet or has moisture in it, shake water off plug and dry properly.

Molex plug must be re-packed with Di-electric grease every time it is unplugged to maintain water resistance.

Correct Wiring Arrangement

The Emitter should have only the blue & brown wires connected to it. The black lead has no connection and should not be wired to the Level Control Relay (LC1).

The Receiver should have the blue, brown & black wires connected.

Correct Voltage

With Level Control Relay plugged in and power to Ice Flaker on, remove wire leads from the Emitter and the Receiver.

Use a voltmeter to verify 24 volts across Blue and Brown terminals. Alternatively you can check terminals #1 and #10 on the Level Control Relay.

If 24 volts is not present, the Level Control Relay has likely failed and needs to be replaced.

Sequence of Operation

There are Light-Emitting Diode (LED) indicators on the rear of both the Emitter & Receiver.

The Emitter has a green LED, which is illuminated whenever the Ice Flaker has power.

The Receiver has two LEDs. The green LED is always illuminated whenever the Ice Flaker has power. The amber LED is illuminated when it “sees” the infrared signal from the Emitter.

During Normal Operation, all LEDs should be lit. The Level Control Relay (LC1) should open the Solenoid Valve, and the Ice Flaker should begin making ice.

When the infrared beam is blocked, both green LEDs will remain lit. However, the amber LED on the Receiver will go out.

After 15 seconds of the beam being blocked, the Solenoid Valve will de-energize and the Off-Delay Cycle will begin.

Depending upon the adjustment of the Off-Delay Setting, the Driver Motor and Water Pump will continue to operate for between 2 – 30 minutes.

If the Photo Eyes do not operate in this fashion, please consult the Troubleshooting section.

Mechanical Operation

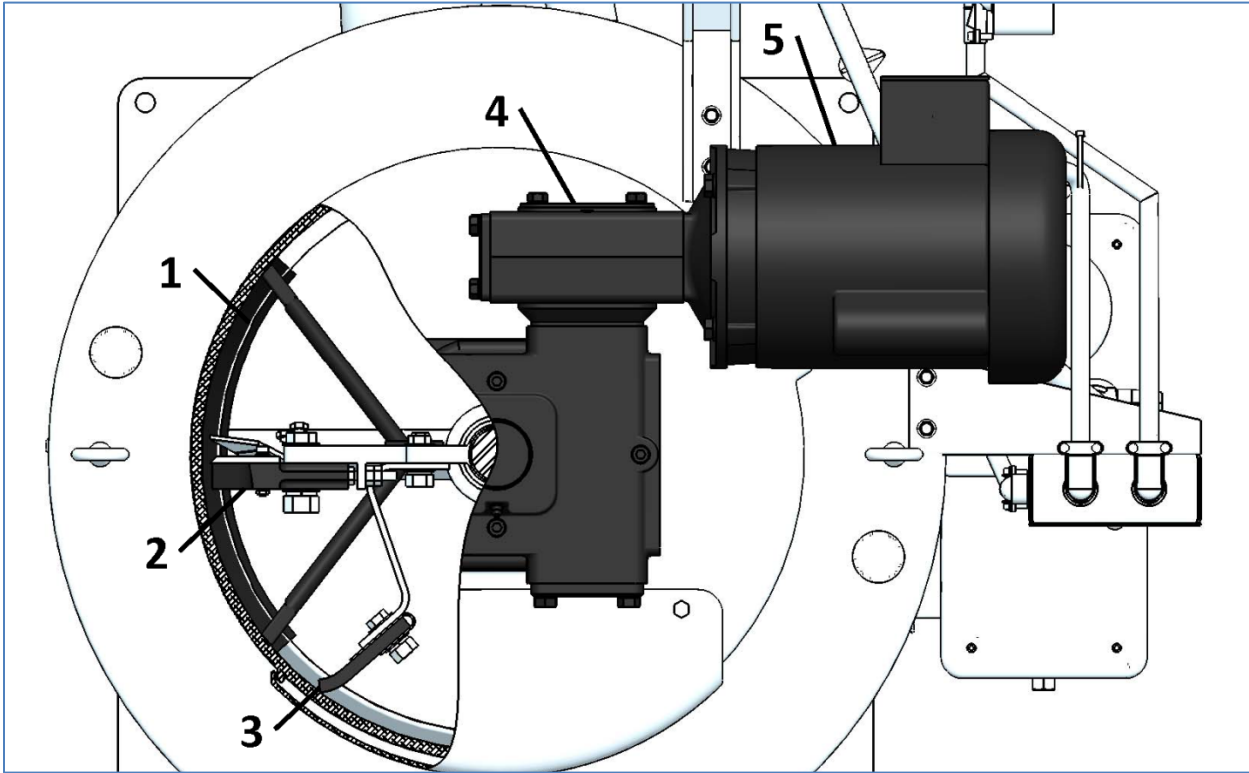

- 1. Ice Deflector
- 2. Ice Blade
- 3. Squeegee

- 4. Speed Reducer
- 5. Drive Motor

Ice Deflector

The Ice Deflector prevents ice from dropping into the water return trough.

A properly installed Ice Deflector should have the top outer edge positioned outside of the ice drop zone to ensure all falling ice will hit the Ice Deflector.

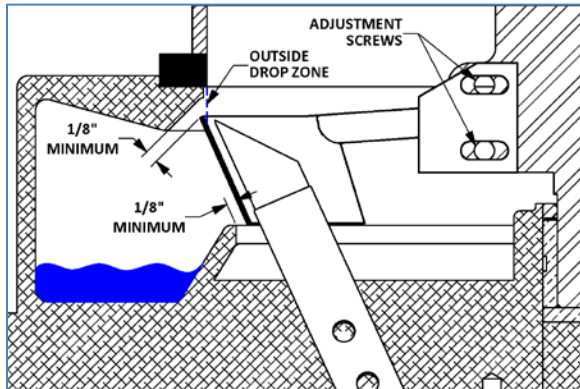

Section View of Ice Deflector

There should be a minimum 1/8" clearance between the top of the Ice Deflector and the aluminum lip of the Bottom Casting under the Evaporator.

There should also be a minimum 1/8" clearance between the outer edge of the Ice Deflector and the Bottom Casting.

The Ice Flaker also features an Ice Deflector Scraper. This plastic arm clears any excess buildup of ice on the Ice Deflector as it passes by the Ice Deflector Scraper.

The Ice Deflector should never touch the Ice Deflector Scraper or the Bottom Casting.

Ice Blade

The Ice Blade shatters the ice formed on the Evaporator freezing surface as the Main Shaft rotates.

Ice harvesting problems are often caused by improper refrigeration settings. Adjusting the Ice Blade should be a last resort after all other means have been expended.

The clearance between the outermost tip of the Ice Blade and the Evaporator freezing surface must be between 0.004" and 0.006".

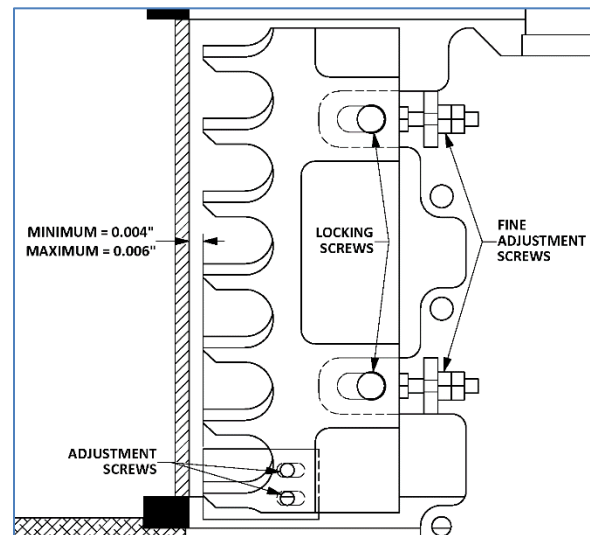

A set of feeler gauges should be used to determine the distance between the Ice Blade and the Evaporator.

Always check the clearance at a minimum of 6 points on the circumference of the Evaporator.

The Auxiliary Ice Scrapers located at the top and bottom of the Ice Blade remove any ice forming in those areas.

The clearance of the Auxiliary Ice Scraper should be the same or slightly greater than the Ice Blade.

Squeegee

The Squeegee wipes excess water from the freezing surface so that the ice is dry upon production.

The Squeegee must be in full contact with the evaporator freezing surface.

Having a Squeegee not in contact with the freezing surface will create wet ice which causes drag on the Ice Blade. This puts greater stress on the Sleeve Bearings and causes them to wear faster than normal.

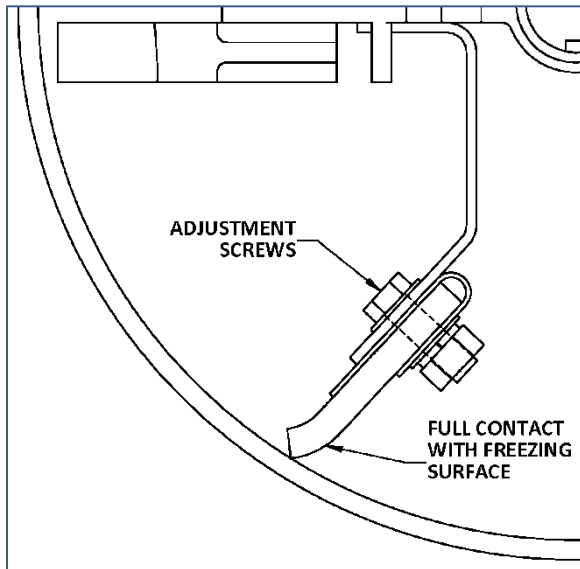

With normal usage, the Squeegee can wear over time. Worn Squeegees need to be trimmed or replaced.

Drive Motor and Speed Reducer

The Drive Motor is attached to the Speed Reducer by (4) mounting screws. There are no other screws or pins holding the Drive Motor in place.

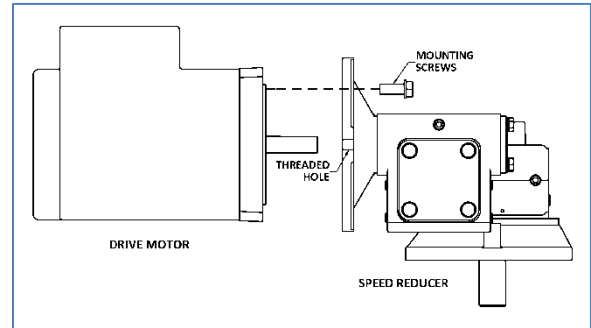

Drive Motors may provide a good deal of resistance when being removed. There are (2) threaded holes on the face of the Speed Reducer in which the mounting screws can be inserted to help push the Drive Motor away.

One motor power lead for the Drive Motor should pass through the Overload Sensing Coil on the Control Module (1) time.

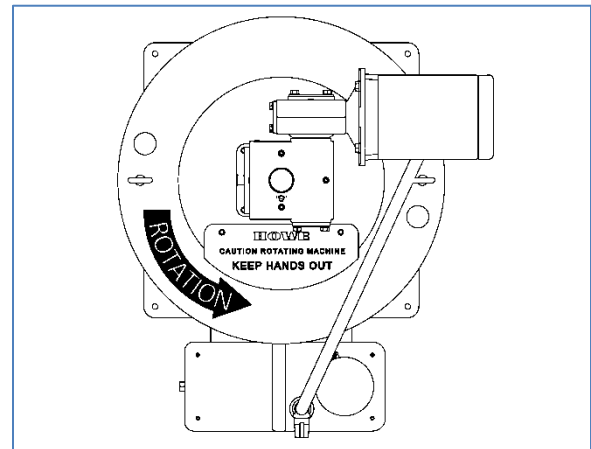

The Drive Motor and Speed Reducer should be placed in the orientation shown above.

Sleeve Bearings

Ice Flakers have two Sleeve Bearings on the Main Shaft located in the Top Casting and the Bottom Casting.

Over time, normal usage can cause these bearings to wear.

Worn bearings can result in ice harvesting problems and even damage to the Evaporator.

Improper refrigeration setting and lack of maintenance can cause the Sleeve Bearings to wear faster than normal.

Please contact Howe to receive the Sleeve Bearing Replacement Instructions for your model Ice Flaker.

Howe is proud to offer our Factory Rebuild Program as an alternative to replacing parts such as the Sleeve Bearings in the field.

Start-Up Checklist

- 1. Is the operating water level in the Water Sump correct?**
(see Float Valve p. 13)
- 2. Is the operating water level in the Water Distribution Pan correct?**
(see Water Distribution Pan p. 14)
- 3. Is the Stop Valve on the Sump Drain connection closed?**
(see Stop Valve p. 13)
- 4. Have you run a Field Capacity Check?**
(see Field Capacity Check p. 16)
- 5. Have you set the Off-Delay Setting on the Control Module?**
(see Off-Delay Setting p. 19)
- 6. Have you set the Motor Overload Setting on the Control Module?**
(see Motor Overload Setting p. 19)
- 7. Have you verified proper Sequence of Operation by the Photo Eye sensors?**
(see Sequence of Operation p. 21)
- 8. Have you verified proper rotation by the Gear Motor or Drive Motor?**
(see Drive Motor and Speed Reducer p. 24)
- 9. Have you completed and returned the Ice Flaker warranty registration?**

Maintenance

Preventative Maintenance Schedule

	Page Number	Every 3 Months	Every 6 Months	Every 12 Months
Lubricate Sleeve Bearings	30	•		
Ensure Float Valve is unclogged and flowing freely	13		•	
Verify correct Sequence of Operation of Photo Eye sensors	21		•	
Clean and Sanitize Ice Flaker	28		•	
Replace Water Filter Cartridge	32		•	
Run a Field Capacity Check	16			•
Verify Ice Blade Clearance	23			•
Check Squeegee for excessive and uneven wear	24			•
Check Main Shaft for movement and Sleeve Bearing wear	25			•

Cleaning Procedure

To keep the evaporator in peak performance, the Ice Flaker should be cleaned every 6 months or more often if water conditions dictate.

Only use cleaning solutions that are labeled as “Nickel-Safe”.



1. Turn the Power Switch “Off” at the Ice Flaker Control Panel.
2. Open Ice Flaker Control Panel and turn Off-Delay timer knob fully clockwise to 30 minutes run time.



3. Remove all ice from Ice Bin.



4. Close water supply at shut-off valve.

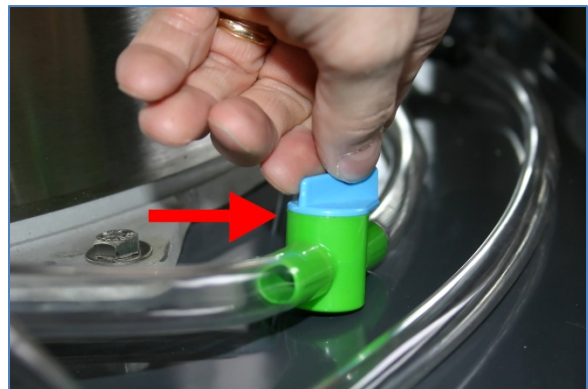

5. Open Ice Flaker Stop Valve to allow water to exit from Water Sump. Afterwards close Stop Valve to prevent loss of solution.



6. Prepare approved cleaning solution by following manufacturer’s instructions.



Sanitizing Procedure

1. Mix 16 oz. of household bleach with 2 gallons of warm water (90°F – 115°F).
 2. Pour solution into the Water Sump to the normal operating level, then re-circulated the sanitizing solution for approximately 20 minutes by turning on Drive Motor and Water Pump.
 3. Drain solution and rinse thoroughly with fresh water at least twice, following the technique described in Cleaning Procedure #10.
 4. After the Ice Flaker is thoroughly rinsed, return to normal operation by opening water supply valve, re-adjusting Off-Delay Setting, and restoring refrigeration by turning the Power Switch back to “On”.
7. Pour cleaning solution into Water Sump to a level just below the side opening.
 8. Turn Power Switch “On” for 2-3 seconds and then “Off” again at Ice Flaker Control Panel. This will allow cleaning solution to circulate for 30 minutes. It may require several 30 minute cycles to fully clean the Ice Flaker.
 9. After cleaning, drain solution as shown in Step 5 except keep Stop Valve open.
 10. Fill Water Sump with fresh water. Turn Power Switch “on” for 2-3 seconds and then “Off” again at Ice Flaker Control Panel. This will flush cleaning solution from Ice Flaker while it is being drained.
 11. Continue filling Water Sump with fresh water until all cleaning solution is flushed out.

Alternate Method: Substitute an approved sanitizer designed for general use in food dispensing equipment in step #1. Mix sanitizing solution according to instructions on the bottle.

Lubrication

Speed Reducer Lubrication

All speed reducers are to be filled with Mobil Glygoyle 460 Lubricant only.

When adding or changing oil for any reason, it should be remembered that oils of various types are not compatible with Mobil Glygoyle 460.

Proper oil level is maintained to the Allen head setscrew on the horizontal center line of the Speed Reducer. Oil should drain out when setscrew is removed.

Add oil through top Allen head screw opening until oil seeps out of centered screw opening.

Do not overfill.

Sleeve Bearing Lubrication

The bearings should be greased annually using USDA approved food grade edible grease.



Typically, only one squirt of the grease gun is required or until you feel resistance on the pump.

Use caution to ensure the bearings is not over-greased.

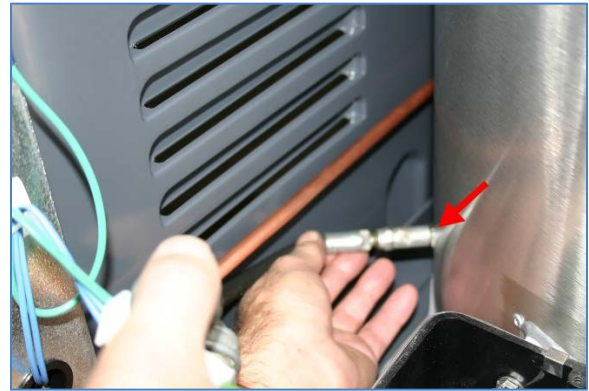

Over-greasing may “pop” the seal out of its normal position.

If over-greased and the seal is popped out of position, the excess grease will need to be removed prior to re-installing the seal.

If seal is damaged due to over-greasing it may need to be replaced.

Water Filtration

The purpose of water filtration is to keep the Ice Flaker clean and operating efficiently.

The value to the user is reduced operating cost due to less maintenance, improved performance and a greater return on investment as result of extended asset life.

There are three primary categories of contaminants that damage and cause the Ice Flaker to operate inefficiently. They are listed here in order of importance with regard to impact.

1. Scale
2. Sediment
3. Chlorine

Scale

Scale or fouling is the accumulation of unwanted material on solid surfaces to the detriment of function. Scale is primarily made up of calcium and magnesium hardness compounds.

It's estimated that scale is responsible for 70% of unscheduled maintenance, inefficient operation, and down time.

Scale forms on wetted surfaces, accumulates in tubing and fittings and interferes with operation.

Sediment

The formation of scale from dissolved minerals is made worse by sediment.

Sediment is suspended particles of dirt, silt and other fine particulate matter that act as a catalyst for scale to form.

Sediment can be detrimental to the condition and performance of the Ice Flaker. Particulates

cause added wear on parts and can clog valves and impede flow.



The effects of scale and sediment can be very destructive to the Ice Flaker.

Chlorine

Chlorine is the most common disinfectant used to kill pathogenic organisms in order to make our water safe to drink. However, residual free chlorine in water can contribute to pitting, rust and corrosion of stainless steel.



If not removed from water, chlorine mixes with moisture in the Ice Flaker and Ice bin to form a mild hydrochloric acid. This acid can cause surface rust to form on stainless steel surfaces in one to two years.

Howe Water Filters

Howe offers a complete line of water treatment systems designed to extend the life and performance of the Ice Flaker.

Howe Water Filters inhibit the formation of scale and provides additional corrosion protection.

They remove 95% of all dirt, rust, and sediment larger than 5 microns.

They reduce chlorine to less than 2 PPM to guard against corrosion and improve ice quality.

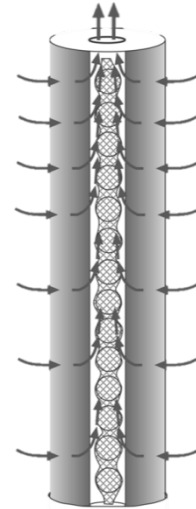

Water Filter Cartridge Replacement

1. Turn off water filtration system by closing ball valve.
2. Press the red button to release pressure.
3. Remove housing(s) – use filter wrench if necessary. Clean housings with warm water. If desired, disinfect housings using 1/2 teaspoon of household bleach in a bowl of water. Let stand 5 minutes, and then discard.
4. Insert new cartridges into filter housings. Match cartridge model numbers to model numbers on bracket.
5. Make certain the O-ring is properly positioned and reinstall filter housing (hand tighten only).
6. Slightly open the inlet ball valve; push the red pressure relief button to release trapped air until a small amount of water comes out – release the red button and fully open the ball valve.
7. Turn connected equipment back on.

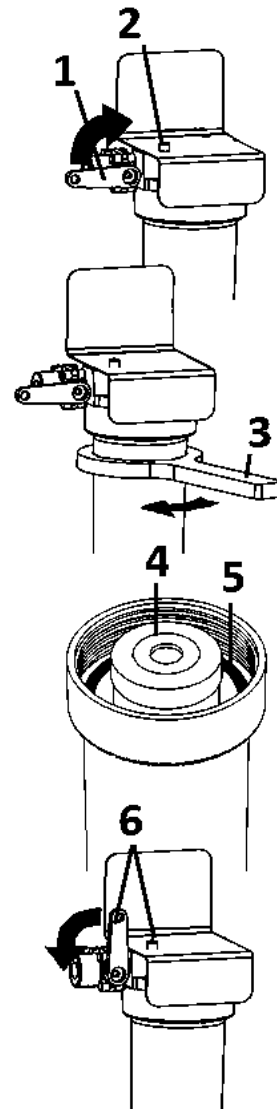

Electronic Valve Settings

CO₂ systems feature two step motor operated valves. Each valve has its own standalone controller. The controllers come factory set for the recommended settings, therefore no adjustment should be required.

If the controllers need to be reset at any time, the factory settings for each controller are below. To access the setpoint menu, press and hold the knob for 5 seconds and enter '111' for the password.

From this menu the setpoints can be changed to the factory settings. To exit the menu and save settings, scroll the knob until 'ESC' appears and press the select knob. This will save any changes. The menu has a 60 second timeout for inactivity. When the timeout is reached, the controller will go back to showing process values and does **not** save any setpoint changes.

Pressure Control (EPR) Setpoints

Displayed Menu Item	Description	Factory Setpoints
ESC	Escape and Save Settings	-
PSP	Pressure Setpoint	260
APPL	Control Application	EPr
PCAL	Pressure Calibration Offset	0
Prng	Pressure Sensor Range	500
StEP	Valve Steps	2500
U_HI	Maximum Valve Position	100%
U_Lo	Minimum Valve Position	5%
PSiH	Pressure Input High Alarm Value	500
PSiL	Pressure Input Low Alarm Value	200
Un_P	Pressure Units (psi or bar)	PSI
Un_t	Temperature Units (F or C)	FAHr
PrUd	Pressure Rise Valve Direction	oPPr
Pdd	Pumpdown Direction	CLPd
SEFP	Sensor Error Failsafe Position	50%
Ctrl	Auto/Manual PID Control	Auto

Kelvin II (EEV) Setpoints

Displayed Menu Item	Description	Factory Setpoints
ESC	Escape and Save Settings	-
SHSP	Superheat Setpoint	5
rEFr	Refrigerant	R744
d_On	Delay On	0
dOFF	Delay Off	0
d_St	Delay Step Position Open of Valve	0%
b_St	Bleed Step Position of Valve %	0.0%
b_dL	Bleed Delay Time	0 sec
L_oP	Low Operating Pressure	0
H_oP	Maximum Operating Pressure	500
C_in	Cut-in Temperature	-59
Cout	Cut-out Temperature	-60
ront	Minimum Relay On Time	0
roFt	Minimum Relay Off Time	0
H.CP	Max Valve Capacity	100%
SUPS	Supermarket Mode	OFF
dbnd	Superheat Control Deadband	2
-P-	Proportional Coefficient	40
-I -	Integral Coefficient	25
-d-	Derivative Coefficient	5
StEP	Valve Type	2500
Un_P	Pressure Units	Psi
Un_t	Temperature Units	FAHr
Tt4P	Temperature Sensor Type	tYP3
Pt4P	Pressure Sensor Type	gAUg
Prn9	Pressure Sensor Range	500
CALP	Pressure Sensor Calibration Offset	0
CLt1	Suction Temperature Calibration Offset	0

Troubleshooting

(Note: All wire colors are subject to change)

Problem	Possible Cause	Possible Solution
Ice Flaker will not run	<ol style="list-style-type: none"> 1. Unplugged or defective Photo Eye(s). 2. Defective Level Control Relay (LC1). 3. No control power from Transformer (T1). 4. Open switch or loose wiring. 5. Defective Control Module (CM). 	<ol style="list-style-type: none"> 1. Ensure Photo Eyes are properly and securely connected. Place a wire jumper between terminals labeled "Blue" and "Black" it the Control Panel. If Ice Flaker starts, Photo Eyes may be defective and need to be replaced. 2. Place a wire jumper between terminals #5 (red) and #6 (red) at the Level Control Relay (LC1). If Ice Flaker starts, Level Control Relay (LC1) may be defective and need to be replaced. 3. Check voltage across Term 1 (purple) and Term 2 (yellow/orange) at Control Module (CM). If 24 VAC not present, Transformer (T1) may be defective and need to be replaced. 4. Place a wire jumper between Term 2 (yellow/orange) and Term 3 (red) at Control Module (CM). If Ice Flaker starts, trace voltage from Term 3. Check all wire terminals and tighten as necessary. 5. Place a wire jumper between Term 2 (yellow/orange) and Term 3 (red) at Control Module (CM). If Ice Flaker does not start, Control Module (CM) may be defective and need to be replaced.
Ice Flaker does not shut down when Ice Bin is full	<ol style="list-style-type: none"> 1. Defective Emitter Photo Eye. 2. Defective Receiver Photo Eye. 3. Level Control Relay (LC1) is jumped out. 4. Defective Control Module (CM). 	<ol style="list-style-type: none"> 1. Unplug Emitter Photo Eye and wait longer than Off-Delay setting. If Ice Flaker stops, Emitter Photo Eye may be defective and need to be replaced. 2. Unplug Receiver Photo Eye and wait longer than Off-Delay setting. If Ice Flaker stops, Receiver Photo Eye may be defective and need to be replaced. 3. Check for a wire jumper between terminals #5 (red) and #6 (blue) at Level Control Relay (LC1). If present remove wire jumper. 4. Remove wire from Term 3 (red) at Control Module (CM) and wait longer than Off-Delay setting. If Ice Flaker does not stop, Control Module (CM) may be defective and need to be replaced.
Solenoid Valve will not open	<ol style="list-style-type: none"> 1. Defective Control Module (CM). 2. Blown Fuses. 3. Defective Water Pump Relay (R1). 4. Defective Solenoid Valve. 5. Loose wiring. 	<ol style="list-style-type: none"> 1. Verify 24 VAC present across Term 1 (purple) and Term 3 (red) at Control Module (CM). Remove wires and check for continuity between Term 7 (black) and Term 8 (red). If the contacts remain open, Control Module (CM) may be defective and need to be replaced. 2. Check for control voltage across FU1 fuses. Replace as needed. 3. Place a wire jumper between terminals #14 (black) and #21 (black) at Water Pump Relay (R1). If Solenoid Valve opens, Water Pump Relay (R1) may be defective and need to be replaced. 4. Verify control voltage at terminals Sol A1 and Sol A2 in the Control Panel. If voltage is present, Solenoid Valve may be defective and need to be replaced. 5. Check all wire terminals and tighten as necessary.

Problem	Possible Cause	Possible Solution
Drive Motor will not run or Ice Flaker in Overload Condition	<ol style="list-style-type: none"> 1. Defective Control Module (CM). 2. Defective Drive Motor. 3. Sleeve Bearings are seized. 4. Speed Reducer is seized. 5. Motor Overload setting is too low. 6. Loose wiring. 	<ol style="list-style-type: none"> 1. Verify 24 VAC present across Term 1 (purple) and Term 3 (red) at Control Module (CM). Check voltage between Term 1 and Term 6 (blue). If no voltage present, Control Module (CM) may be defective and need to be replaced. 2. Verify control voltage at terminals T1 Driv and T2 Driv in the Control Panel. If voltage is present, Drive Motor may be defective and need to be replaced. 3. Remove the Gear Motor from the Mounting Hub or the Speed Reducer from Top Casting and try to push the Ice Blade by hand. If the Ice Blade will not move, the Sleeve Bearings may be seized and need to be replaced. 4. Remove Speed Reducer and bring voltage to the Drive Motor. If the output shaft cannot turn while not attached to the Ice Flaker, it may be seized and need to be replaced. 5. Raise the Motor Overload setting at the Control Module (CM). Verify the amperage draw is in correspondence with the nameplate. 6. Check all wire terminals and tighten as necessary.
Water Pump will not run	<ol style="list-style-type: none"> 1. Defective Control Module (CM). 2. Blown Fuses. 3. Defective Water Pump. 4. Loose wiring. 	<ol style="list-style-type: none"> 1. Verify 24 VAC present across Term 1 (purple) and Term 3 (red) at Control Module (CM). Check voltage between Term 1 and Term 6 (blue). If no voltage present, Control Module (CM) may be defective and need to be replaced. 2. Check for control voltage across FU1 fuses. Replace as needed. 3. Verify control voltage at terminals T1 Pump and T2 Pump in the Control Panel. If voltage is present, Water Pump may be defective and need to be replaced. 4. Check all wire terminals and tighten as necessary.
Ice does not harvest at the bottom of Evaporator	<ol style="list-style-type: none"> 1. TXV is underfeeding. 2. System is short of refrigerant. 3. Improper location of TXV sensing bulb. 	<ol style="list-style-type: none"> 1. Adjust refrigeration to Ice Flaker. 2. Check for bubbles in the Sight Glass. If present, charge system as needed. 3. Relocated bulb to 4:30 clock position as originally set by factory.
Ice does not harvest on one side or angular section of Evaporator	<ol style="list-style-type: none"> 1. Sleeve Bearings are worn. 2. Ice Blade clearance is too high. 	<ol style="list-style-type: none"> 1. Remove Speed Reducer or Gear Motor and check for "play" in Sleeve Bearings. Replace if worn. 2. Adjust Ice Blade clearance to proper setting.
Ice accumulates on the ribs of Bottom Casting	<ol style="list-style-type: none"> 1. Ambient Temperature is too low. 	<ol style="list-style-type: none"> 1. If ambient temperature is below 50°F, relocate Ice Flaker to a warmer area. Contact Howe about Low Ambient Kit.
Ice Blade is frozen in-place	<ol style="list-style-type: none"> 1. Motor Overload setting is too high. 2. Ice is freezing too thick or too hard. 3. Drive Motor has stopped. 4. Flex Coupling is broken. 	<ol style="list-style-type: none"> 1. Adjust the Motor Overload setting at the Control Module (CM). 2. Adjust refrigeration to Ice Flaker. 3. See "Drive Motor will not start" above. 4. Check and replace Flex Coupling as necessary.

Problem	Possible Cause	Possible Solution
Ice Flaker not meeting rated capacity	Run Field Capacity Check before making any adjustments (see p.16).	
	<ol style="list-style-type: none"> 1. Incorrect Evaporator Temperature. 2. Supply water temperature is outside mandatory range. 3. Ambient temperature is outside mandatory range. 	<ol style="list-style-type: none"> 1. Adjust refrigeration to Ice Flaker. 2. Adjust supply water to between 45°F and 90°F. For temperatures below range, contact Howe about Low Temperature Mixing Valve. 3. Adjust ambient temperature to between 50°F and 100°F. In unable to adjust, relocate the Ice Flaker. For temperatures below range, contact Howe about Low Ambient Kit.
Ice freezes together in the Ice Bin	<ol style="list-style-type: none"> 1. Water Distribution Pan is overflowing. 2. Water from Side Spouts or Lead Spout is not reaching freezing surface of Evaporator. 3. Water is “ramping” off rings of ice formed on Evaporator. 4. Ice Bin is not draining properly. 5. Ice turnover is low and Ice Bin inventory has become stale and clumped by lengthy storage time. 	<ol style="list-style-type: none"> 1. Adjust Water Regulating Valve so the Water Distribution Pan is halfway full. 2. Clean spouts of any debris or blockages. Make sure all spouts are perpendicular to and within reasonable distance from surface of Evaporator. 3. Adjust refrigeration to the Ice Flaker. 4. Check that all drains are flowing freely and pitched away from Ice Bin. 5. Use or discard ice within a reasonable time of producing it. Contact Howe about Energy Saver Ice Production Management System.

Appendix

Cut View

Item No.	Part Description
1	Auxiliary Ice Scraper
2	Bottom Casting
3	Drive Motor
4	Evaporator
5	Float Valve
6	Ice Blade
7	Ice Deflector
8	Ice Deflector Scraper
9	Lead Spout
10	Main Shaft
11	Side Spout
12	Sleeve Bearing
13	Speed Reducer
14	Top Casting
15	Water Distribution Pan
16	Water Pump
17	Water Regulating Valve
18	Water Sump

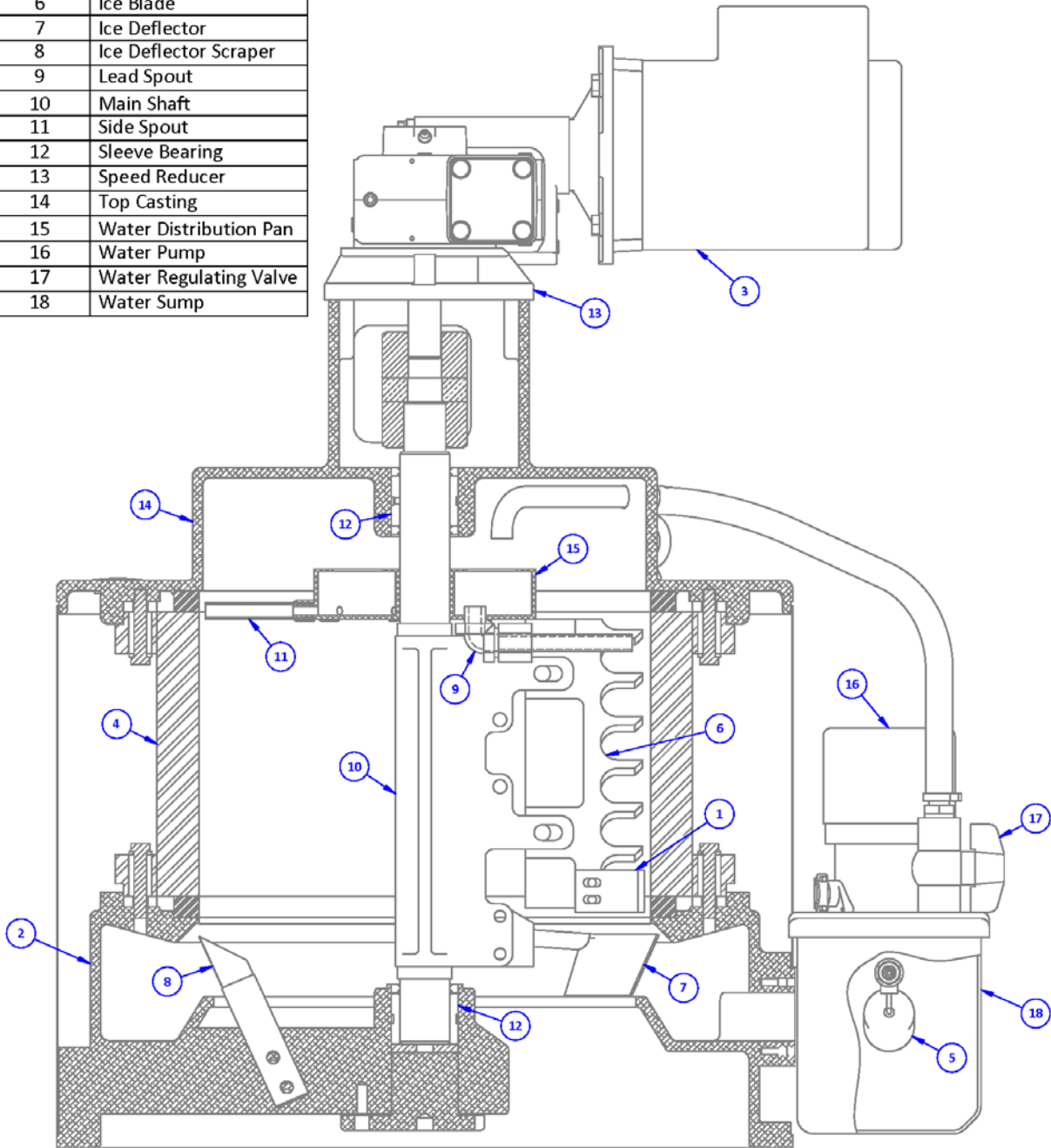

Wiring Diagram - Main Ice Flaker Control Panel

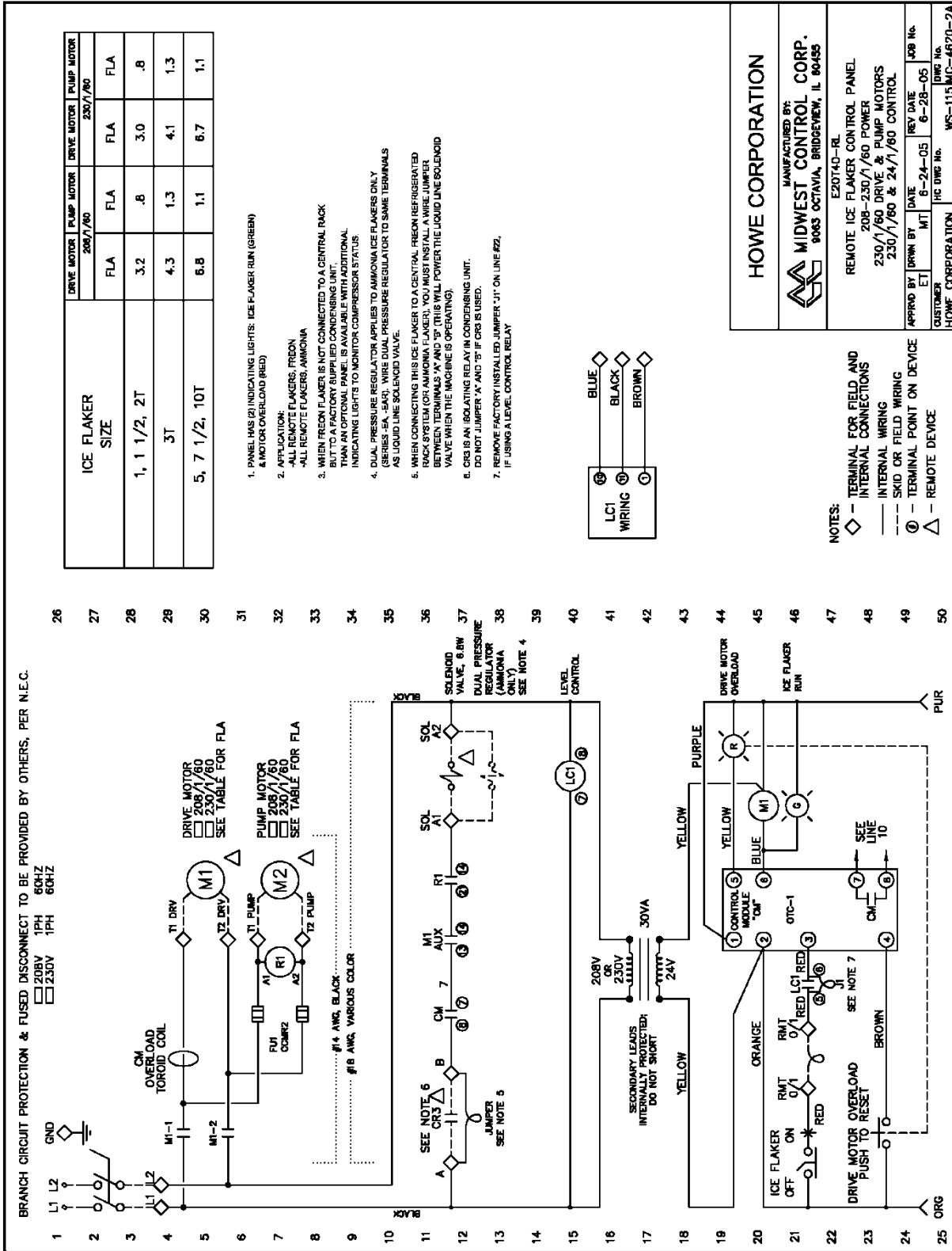

Wiring Diagram- CO2 EEV/EPR Control Panel

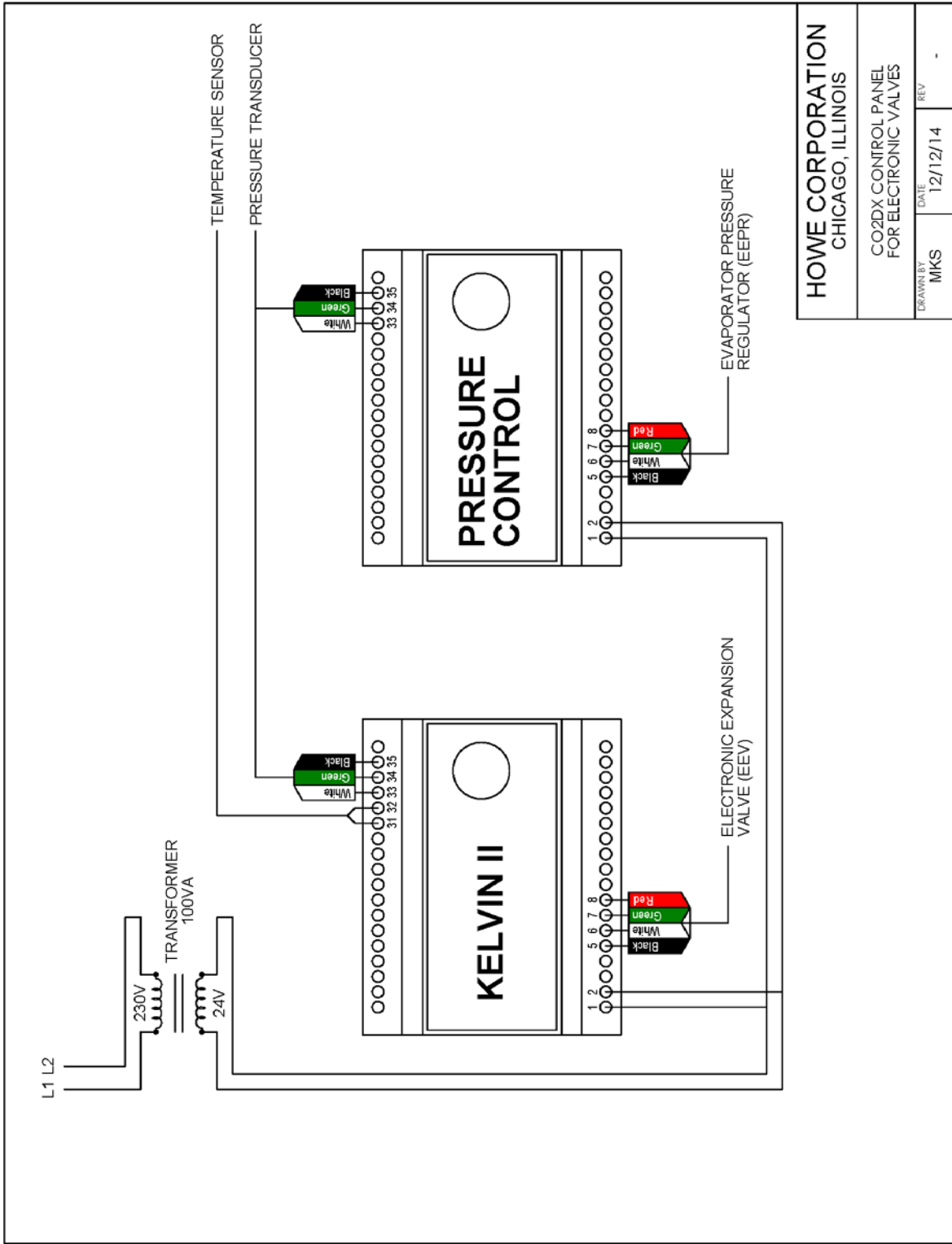

HOWE CORPORATION CHICAGO, ILLINOIS	
CO2DX CONTROL PANEL FOR ELECTRONIC VALVES	
DRAWN BY MKS	DATE 12/12/14
	REV -

