

Rapid Freeze

Moderate Ambient Air Cooled

50 hz Condensing Units

COOL SOLUTIONS SINCE 1912

HOWE Proven. Best Choice.



MA4002-A-R404A-2 shown.

Howe's high ambient condensing units are sized and configured to match Howe Rapid Freeze ice flakers. These units are designed for unexcelled quality, reliability, and long life. They are durable, energy efficient and they provide a high degree of flexibility to a wide diversity of industrial applications.

STANDARD FEATURES

- High efficiency Copeland scroll compressors with POE Oil.
- Thermally protected permanently lubricated ball bearing condenser fan motors.
- Electrical controls in weatherproof control box with compressor contactor and fused control circuit.
- Head pressure control system
- Suction & liquid vibration eliminators.
- Liquid line filter-drier and sight glass.
- Hail Guard included

SPECIAL FEATURES

- Pump down toggle switch
- Suction Accumulator
- Oil Separator with oil return line.
- Separate high pressure, low pressure control switches
- Oversized condensing units rated for 95°F ambient conditions.

OPTIONAL FEATURES

- Coated condenser coils for harsh environments.
- Oversized condensing units rated for 110°F ambient conditions. (See high ambient spec sheet)
- Cold Ambient units available for low temperature climates. (See low ambient condensing unit spec sheet).

Moderate Ambient - 50Hz

AC Condensing Units

SIDE VIEW

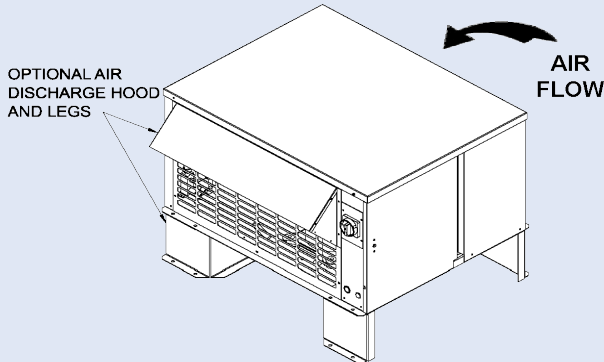

END VIEW

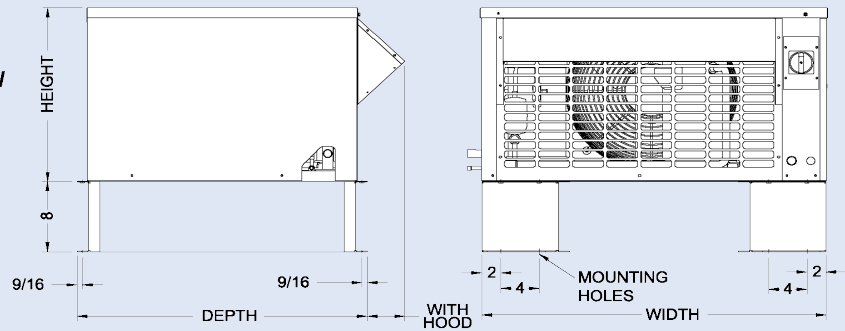

CONDENSING UNIT

MODEL	DIMENSIONS IN			DIMENSIONS CM			CONDENSING UNIT CONNECTION SIZES		REQUIRED RUN LINE SIZES		SHIPPING WEIGHT		REC. CAP. 90% LBS.
	W	D	H	W	D	H	SUCTION	LIQUID	SUCTION	LIQUID	LBS	KG	
MA1002-A-R4xxA-2	36-3/8	30-3/8	19-3/8	92.39	77.15	49.21	7/8	3/8	7/8	3/8	425	143	11
MA2002-A-R4xxA-2	43-7/8	32-7/8	30-3/8	111.44	83.5	77.15	1-1/8	1/2	1-1/8	1/2	440	200	22
MA3002-A-R4xxA-2	43-7/8	32-7/8	30-3/8	111.44	83.5	77.15	1-1/8	1/2	1-3/8	1/2	495	225	30
MA4002-A-R4xxA-2	52-1/8	35-7/8	41-7/8	132.40	91.12	106.36	1-3/8	5/8	1-3/8	1/2	545	247	30
MA6002-A-R4xxA-2	65-1/8	35-7/8	41-7/8	165.42	91.12	106.36	1-3/8	5/8	1-5/8	5/8	745	338	54

xx= 04 for R404a, 48 for R448A, 49 for R449A,

ELECTRICAL

VOLTAGE	MODEL	COMPRESSOR		CONDENSER FAN MOTORS			UNIT		
		RLA	LRA	QNT.	WATT	FLA (EACH)	FLA (EACH)	MCA	MOP
380/3/50	MA1002-A-R4xxA-2	5	32	1	240	.6	5.6	7.0	12.7
	MA2002-A-R4xxA-2	8.6	64	1	400	1.1	9.7	12.1	21.7
	MA3002-A-R4xxA-2	11.9	102	1	400	1.1	13	16.2	29.1
	MA4002-A-R4xxA-2	14.4	121.4	1	400	1.1	15.5	19.3	34.8
	MA6002-A-RxxA-2	20.2	139	2	800	2.1	24.4	30.5	54.9

¹ = Receiver capacity is based on R404A refrigerant. Multiply R404A value by the appropriate value below for alternate refrigerants:

R407A	R407C	R448A	R449A	R507	R22
1.10	1.10	1.05	1.05	1.0	1.15