

HOWE®

Rapid Freeze® Ice Flakers

Replacement Parts list

For model
2000-RL-P

Howe Corporation
1650 N Elston Ave
Chicago, Il.60642





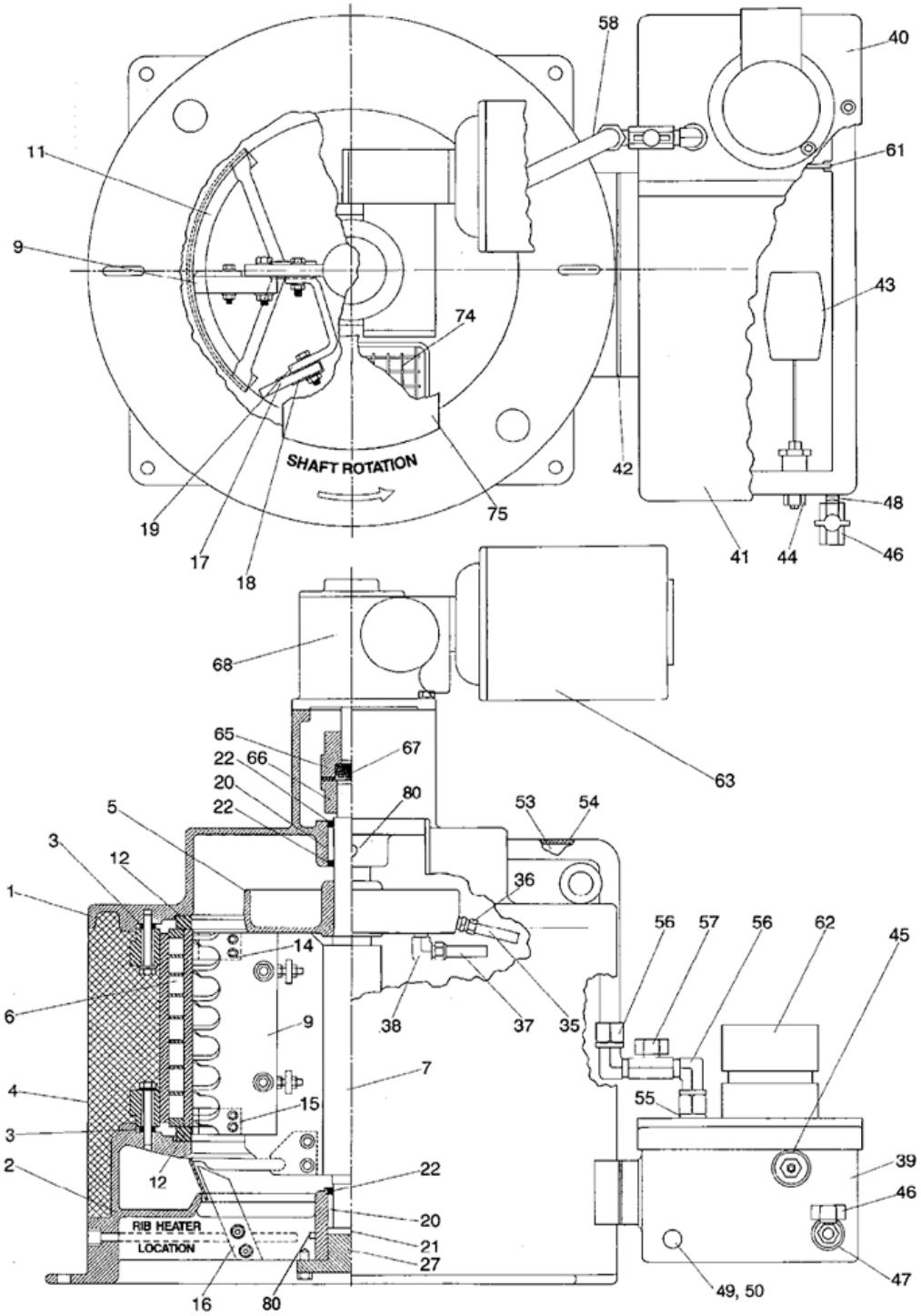









email: parts@howecorp.com
Service@howecorp.com













Main Tel: 773.235.0200
Parts: 773.687-4950
Service: 773.687.4940



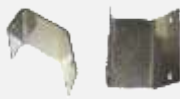





















Drwg #	Drwg Ref Num	Part Number	Description	Qty	Image of Part
--------	--------------	-------------	-------------	-----	---------------

2000-RL-P

a	0	F5H25-4	Water Sump Cover - Removeable access side	1	
a, b	0	E10H59	Water Pump regulating valve	1	
a, b	0	E10H79	Water Float Valve	1	
	0	53009	Semi Annual Maintenance kit (Includes, cleaner, grease, water filter)	1	
	0	53010	Annual Maintenance kit (Includes, cleaner, sanitizer, grease, water filter, ice blade adjustment kit)	1	
b	3	E20J4	Insulated Lug Spacers	8	
	7	E10D2	Main Shaft for 2000	1	
b	9	E10E2	Ice Blade 8.5" Long	1	
b	0	E10E5	Nuts, Bolts & Washers for E10E2 ice blade	1	
	0	E10E15	Ice Blade Adjustment gauge Kit (set of 7 gauges)	1	
b	110	E10G1	Ice Deflector (2-3K)	1	
b	0	E20G5	Ice deflector nuts, bolts & washers (only)	1	
b	12	E10J1	Rubber Insulating Ring	2	
	0	E10J8	Insulating Ring Repair Tool	1	

Drwg #	Drwg Ref Num	Part Number	Description	Qty Rea	Image of Part
b	14	E20E4	Top or Bottom Axillary ice Scraper	2	
b	0	E20E7	Axillary Ice Scraper nuts, Bolts & Washers (only)	2	
b	17	53027	Squeegee Repair Kit,(Squeegee, Wrapper, Nuts, bolts & Washers)	1	
b	17	E10F4	Squeegee 8.5" long	1	
b	0	E10F4-OZ	Squeegee 8.5" Long (Ozone Resistant)	1	
b	18	E10F9	Squeegee Wrapper 8.5" Long	1	
b	0	E10F8	Nuts bolts & Washers for Squeegee Wrapper	1	
b	19	E10F11	Squeegee Bracket	1	
b	0	E10F7	Squeegee Bracket (Seawater models only)	1	
b	20	E20K1	Main Shaft Sleeve Bearings	2	
b	21	E20K2	Main Shaft Thrust Plate	1	
b	22	E20K3	Main Shaft Grease Seals	3	
b	0	E20K4	Main Bearing Replacement Kit (includes, bearings, seals & plate)	1	
b	0	E10T1	Bearing removal/ replacement tool	1	

Drwg #	Drwg Ref Num	Part Number	Description	Qty Req	Image of Part
b	27	E10B8	Bottom Bearing cover	1	
b	35	E10H18	Water distribution side spout tube & fitting (for old style aluminum distribution pan)	6	
b	35	E10H73	Water Distribution side spout tube (for Plastic Distribution pan)	6	
b	37	E10H17	Water Distribution bottom spout & fitting	1	
b	5	E10H51	Water Distribution Pan assembly (Plastic Pan / tubes)	1	
b	42	E20J2	Water Sump gasket	1	
b	53	E10H67-KT	Water Tube with regulating valve	1	
b	56	ELM-CT-NY10X08	Water tube fitting for copper tubes/horizontal valve	2	
b	57	E10H59	Water regulating valve (for dist. pan level)	1	
b	0	E10H61	Replacement water sump assembly	1	
b	0	E20Q5	Marine duty (Shipboard) replacement water pump	1	
b	63	E20M3	Replacement drive motor 1/3 HP, 230/1/60 (TEFC)	1	
b	63	E20M10	Replacement drive motor 1/3 HP 220/1/50	1	
b	63	E20M11	Replacement drive motor 1/3 HP 240/1/50	1	

Drwg #	Drwg Ref Num	Part Number	Description	Qnt Rea	Image of Part
b	63	E20M2	Replacement drive motor 1/3 HP 380/3/50	1	
b	63	E20M5	Replacement drive motor 1/3 HP 380/3/50 (TEFC)	1	
b	0	E10N4	Flexible coupling	1	
b	68	E10R5	Speed Reducer 600:1 (all 2000, & 3000 - 50 Hz use)	1	
b	75	E10A5	Inspection Cover	1	
b	0	HT150-240- 037X50	Replacement low ambient heater element	3	
b	0	SR-OIL-SYN	Synthetic Speed reducer oil (Quart)	1	
b	0	53057	Liquid Line solenoid valve with coil	1	
b	0	E10C21	Liquid Line Evaporator Connector	1	
	0	53015	3 year maintenance kit (Includes cleaner, sanitizer, food grade grease, water filter, ice blade adjustment kit, and squeegee)	1	
b	0	E10C14	Rotolock sweat adaptor (suction line)	1	