

Howe

E10H55

Water Filter System

Proven. Best Choice.™

System Benefits

- E10H55 is a dual-housing water treatment system with two drop-in 4-1/2" x 20" cartridges that reduces sediment down to 5 microns and reduces chlorine, taste & odor at a flow rate of 5.0 gpm for 50,000 gallons.
- Improves quality and consistency of ice.
- Reduces maintenance frequency and cost, and extends equipment life.
- Gradient-density sediment filtration protects against dirt, rust and other debris down to 5 microns.
- High-capacity activated-carbon filtration makes water taste great and protects equipment against corrosive chlorine.
- Sturdy mounting bracket and full-flow inlet shut-off valve simplify installation.
- Inlet shut-off and depressurization valves make filter replacement quick and simple.
- Minimizes waste by only replacing drop-in cartridge and reusing filter sump.

Water chemistry has a significant impact on the operating efficiency, service requirements and life of your Howe ice flaker. The Howe filtration products help protect against a range of water-related problems and are recommended for all Howe ice flaker installations

There are significant variations in water quality from one region to another. It is the responsibility of the owner/operator of the equipment to assure that the incoming water supply is within the Howe Water Quality Standard. If your water quality is outside the Standard additional water treatment may be required to comply with the standard. Damage to equipment caused by non-compliance with the Howe Water Quality Standard will not be covered by the Warranty.

Installation tips

- Feed-water connection to system should be COLD only.
- Do not exceed system specifications for temperature and pressure.
- Allow 3" clearance below system for filter housing removal and cartridge replacement.
- Detailed installation, operation & maintenance manual included with each system.
- No activation procedure or flushing required for system to perform as specified.

Application

HOWE MODELS:

51, 76, 101, & 201



MADE IN USA!

E10H55

Water Filter System

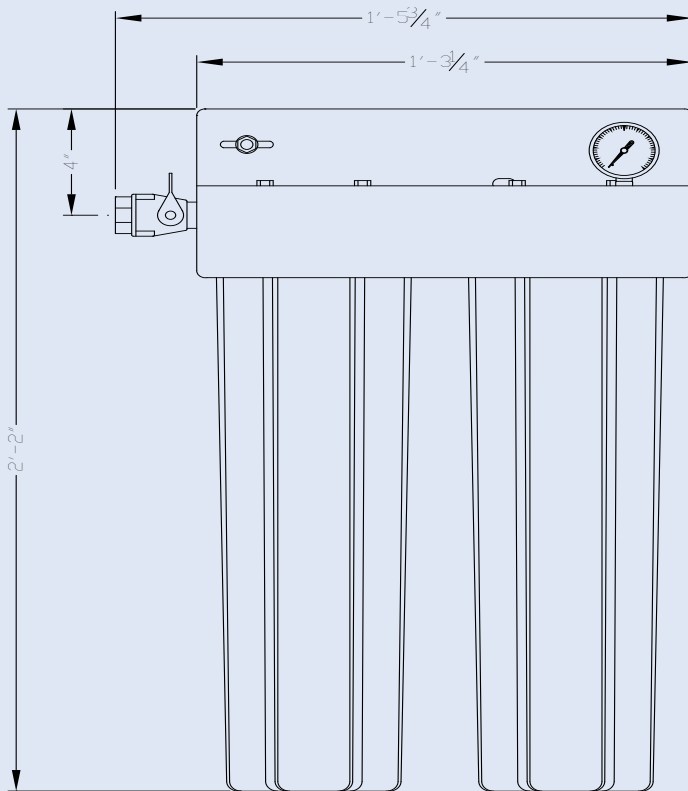

Specifications

System	
Dimensions Height x Width x Depth, inches	25-11/16" x 12-7/16" x 9-7/8"
Connection - Inlet & Outlet	3/4" NPT female
Operating Pressure Range	10-125 psi (0.7 -8.6 bar)
Inlet Water Temperature Range	35 - 100°F (2 - 38°C)
Shipping Weight	24 lbs.
Performance	
Chlorine, Taste and Odor Reduction Capacity	60,000 gals (189,271 liters)
Service Flow Rate	5.0 gpm (18.9 lpm)
Sediment Reduction	5 micron (nominal)
Scale & Corrosion Inhibitor	N/A

Optional Flush Valve Kit - Part #: 160-52910

Replacement Cartridge(s)

Model	Part Number	Qty
	E10H57	2

It is recommended that filters be changed every six months, when capacity is reached or when effluent pressure or flow becomes inadequate.

This product is for commercial use only and must be installed and maintained according to manufacturer's guidelines.

Do not use on water that is microbiologically unsafe or of unknown quality without adequate disinfection before or after the system.

Warranty

Systems have a 3-year warranty against defects in material and workmanship. For complete warranty information, contact OptiPure customer service.

Howe Water Quality Guidelines

Characteristic (mg/l)	Acceptable Range
TDS	40 to 250
Hardness	35 to 125
Alkalinity	35 to 150
pH	7.0 to 8.5
Chloride	75 max
Iron	0.1 max
Chlorine	0.2 max